

Basic Machine Tool Operation Guide



Florida Tech Machine Shop

College of Engineering
Sept. 8, 2011

Table of Contents

	Section Title	Page
1	Florida Tech Machine Shop Rules.....	2
	Work Approval Policy.....	3
	Student Certification.....	3
	First Aid Policy.....	3
2	General Safety Guidelines.....	4
	Guidelines: Working with solvent, resin and other chemicals.....	6
	Guidelines: Heavy sanding of wood and foam.....	7
	Guidelines: Cleaning.....	8
3	Power Tool Safety.....	10
4	Drill Press.....	11
5	Band Saw.....	13
6	Lathe.....	17
	Wood Lathe.....	22
7	Manual Mill	28
8	Grinders.....	35
9	Disc & Belt Sanders.....	39
10	Table Saw.....	41
11	Tile Saw.....	47
12	Chop Saw.....	49
13	Welding.....	61
15	Measuring.....	63
16	Dial Calipers.....	66
17	Using a Micrometer	70
18	Layout.....	73
19	Taps and Dies.....	79
20	Reference.....	85

Florida Institute of Technology

MACHINE SHOP RULES

1. Students are not permitted to work without a Supervisor in the Machine Shop. An approved Florida Tech paid employee must be present at all times.
2. All who enter the shop must sign-in at the office.
3. When working in the shop two people must be present at all times. “Buddy’s” are not to touch machinery controls
4. Safety glasses must be worn at all times. Tinted or Sunglasses are not to be used in the shop.
5. No sandals or open-toe shoes. Work boots or street shoes ONLY.
6. Do not wear loose clothed or jewelry. Tie back long hair.
7. Material Safety Data Sheets must be supplied on materials not listed in shop MSDS book before work can begin.
8. Dispose of waste according to the MSDS sheets and posted signs.
9. No part washing in the sinks. Sinks are for hand washing only.
10. Do not lay rags on lathe or mill.
11. Do not enter the shop under the influence of drugs or alcohol.
12. All metal scraps and cuttings are to be disposed of in the proper recycling drum. Do not put trash or metals of unknown composition into the recycling drum, separate plastics.
13. Do not throw anything away unless you are certain it is unusable. If in doubt ask the Supervisor.
14. Do no enter material storage area without permission.
15. *Accidents and/or machine problems must be reported immediately to the Supervisor. The Lab Director and faculty will be notified to determine possible disciplinary action when failure to report a problem promptly, lying, or false statements take place.*
16. All students must complete a training course to be allowed to operate the equipment. *Untrained students will be limited, as determined by the Shop Supervisor.*
17. Students should never talk on a cell phone while operating equipment.
18. The Supervisor must check all machine setups before machine operation begins.
19. Do not use compressed air for cleaning. Refer to cleaning guide in shop manual
20. No arguing or horseplay in the shop.
21. Work Studies should set an example for shop workers. Therefore rule breaking and/or repeated improper shop practice is reason for dismissal and disciplinary action.
22. No Eating or Drinking in the shop.
23. All tools must be signed out (this includes cutting tools) for use outside of the shop area. You must get the shop Supervisor’s approval before leaving the shop with a tool. All tools must be returned and documented.
24. Students who do not return tools will be subject to university disciplinary action.
25. A work order is required to build parts at the machine shop.

I understand that I must follow all the above safety regulations when working in the machine shop.

Student Signature: _____ Date: _____

Print Name (legibly please): _____

Approved By: _____ Date: _____

Walk-In and Work Request Rules

Walk-in and work order request process is documented in the Machine shop procedure: Standard Operating Procedure, Work Orders, MS-03. It is available at Machine and Welding Shop website at <http://www.fit.edu/machine>

Machine Shop Student Certification

Machine Shop Certification is a formal training program that occurs outside of other class work in the Machine Shop. Standard Operating Procedure, Machine Shop Student Certification, MS-01. It is available at Machine and Welding Shop website at <http://www.fit.edu/machine/>

First Aid Policy

Understanding First Aid is critical to getting help when a situation happens. Machine shop staff is certified in First Aid and CPR. For more information see-Standard Operating Procedure, First Aid Policy, MS-02. It is available at Machine and Welding Shop website at <http://www.fit.edu/machine/>

General Safety Guidelines Class2

1. Do not attempt to remove foreign objects from the eye or body, report to the student health service for medical treatment. If chemicals get in the eye(s), wash eye(s) for 15 minutes in an open flow of water before proceeding for medical treatment.
2. Do not use compressed air to blow dirt or chips from machinery to avoid scattering chips. Never use compressed air guns to clean clothing, hair, or aim the gun at another person.
3. Machines **must be shut off** when cleaning, repairing, or oiling.
4. Keep rags away from moving or rotating machinery.
5. Do not wear ties, loose clothing, jewelry, gloves, etc. around moving or rotating machinery. Long hair must be tied back or covered to keep it away from moving machinery. Hand protection in the form of suitable gloves should be used for handling hot objects, glass or sharp-edged items. **DO not wear gloves while operating machinery**
 *Exception: under special circumstances, with the approval of the machine shop supervisor, thin latex skin tight (correct size) gloves may be worn if required as PPE.
6. Wear appropriate clothing for the job (i.e. do not wear short sleeve shirts or short pants when welding).
7. Do not work in the shop if you are tired or in a hurry – this almost always ruins the work, and often results in injury.
8. Never indulge in horseplay in the shop areas.
9. All machines must be operated with all required guards and shields in place.
10. A brush, hook, or special tool is preferred for removal of chips, shavings, etc. from the work area. **Never** use your hands to clean cuttings – they are sharp!
11. Keep your fingers clear of the point of operation of machines by using special tools or devices, such as, push sticks, hooks, pliers, etc. **Never use a rag near moving machinery.**
12. A hard hammer should not be used to strike a hardened tool or any machine part. Use a soft-faced hammer.
13. Keep the floor around machines clean, dry and free from trip hazards. Do not allow chips to accumulate.
14. **Think through the entire job before starting.** Ask for help if you have questions.
15. Before starting a machine, always check it for correct setup and always check to see if machine is clear by operating it manually, if possible.

16. No drinking or eating in shop area. Do not bring food or snacks into the shop.
17. Do not attempt to operate equipment under the influence of drugs or alcohol.
18. Read and follow the MSDS sheet for any material you are working with
19. If you have not worked with a particular material before, check the materials safety data sheets book for any specific precautions to be taken while working with the material. Also, ask the shop personnel before cutting any unusual material.
20. Heavy sanding and grinding should only be done in well-ventilated areas, preferably on the patio. Painting on the patio only – **make sure that the doors to the shop are closed.**
21. Follow all appropriate precautions when working with solvents, paints, adhesives or other chemicals. Use appropriate protective equipment.
22. Check the power cords and plugs on portable tools before using them.
23. Always store oily rags in an approved metal container.
24. Only one person may operate a machine. The “Buddy” should watch and never activate or touch controls.

Safety Guidelines for Working with Solvents, Resins and other Chemicals

1. Read Engineering contact sheet posted in the office for appropriate phone number.
2. Learn about the chemicals that you are planning to use before opening them. Always read the Instructions and MSDS sheet. Consult shop staff or the University Safety Officer, Greg Peebles if you have any questions.
3. Use water-based cleaners instead of solvents where possible. Solvents are to be disposed of in the solvent waste can. Never wash down the drain.
4. Avoid skin contact. Wear non- latex gloves unless other gloves are required by the MSDS for the material.
5. Work in a ventilated area if possible. Respirators are available when necessary. The University Safety Officer, Greg Peebles can give you the necessary paperwork for an exam at Student health and does respirator fitting.
6. Do not use solvents around hot metal surfaces and flames.
7. Do not smoke or light flames in areas where solvents are used and stored.
8. Report and clean up any spills immediately. Call the University Safety Officer, Greg Peebles.
9. Do not pour any chemicals down the drain. Waste containers are available in the solvent cabinet.
10. Only use solvents in well ventilated areas - do not work with them in confined, unventilated areas.
11. Do not drink alcoholic beverages or take medications containing alcohol before or during working with solvents. Alcohol in the bloodstream sometimes causes synergistic reactions with various solvents that can lead to loss of consciousness, and even possibly, death.
12. Report any ill effects and skin disorders to the area supervisor.
13. Develop and maintain good personal hygiene habits. Remove protective equipment and wash thoroughly after contact with solvents.
14. Fumes from paints, solvents, adhesives, and the abrasive cut-off saw used on the patio can drift into the shop. Work with staff to minimize these problems.
15. Mix resins in small batches.
16. Dispose of used material and brushes in the approved waste bin. Be sure lid closes. Record what the material was on the sheet provided on the waste container.

Safety Guidelines for Heavy Sanding of Wood and Foam

1. Sand in a well ventilated area away from other machines, only on the patio with the doors to the shop closed.
2. Use a vacuum or a dust collector to collect dust **while** sanding to prevent the dispersal over a large area.
3. A dust mask or respirator shall be worn per the MSDS. Contact the University Safety Officer, Greg Peebles for assistance. Dust masks are stored in the safety cabinet.
4. Safety glasses must be worn when sanding.

Guidelines for the Composite Bay

1. Use of 2 part epoxies – room temperature full cure only.(Like West System 102/107)
2. Have individuals using material respirator certified. P100 Respirators must be used during all sanding activities – particularly if epoxy has not completely set.
3. Dust is highly hazardous until mixture has fully set per manufacturer time & tested for proper ratio of mixture. For respirators during application – see MSDS for particular epoxy system for details.
4. Keep bay doors open during application. If application is to be done on outside deck, seal deck surface with plastic film.
5. Sand inside bay only with doors closed
6. Room must be HEPA vacuumed after each session of sanding.

Guidelines for Cleaning Class 1

1. Turn off power to the machine before cleaning. This will avoid accidentally starting the machine and injuring yourself.
2. Remove cutting tools. Take out drill bits, mills and remove lathe tools to reduce the chances of getting cut. On the table saw lower the blade completely.
3. Put away all hand tools and other items around the shop. Keep work area orderly..
4. Clean chips from the tool, the chip pans. Recycle clean chips where possible.
5. Put a light coat of way oil on the machine ways. Ask staff to show you where this oil is kept.
6. Sweep the floor in the area where you have been working.
7. Do not use compressed air unless directed by shop supervisor. Do not blow air into the bearing surfaces, and do not scatter chips all over the shop. Sometimes a shop vacuum works better than the air gun.
8. Report missing, broken or damaged tools to shop staff.
9. Spend your last five minutes on general cleaning around the shop. We're all in this together.

General Safety Guidelines

Electric Hand Tools

Fuel Transport & Storage

Hydraulic Tools

Pneumatic Tools

POWER TOOL SAFETY Class 2

Safety Tips:

- Use the proper tool for the job
- Never carry a tool by the cord or hose
- Keep cords and hoses away from heat, oil, or sharp edges
- Disconnect tools when not in use, before servicing and when changing accessories
- Keep all guards in place and make sure they are working properly
- Wear proper apparel. Loose clothing, long hair, and jewelry can become caught in moving parts
- Wear personal protective equipment, including safety glasses and hearing protection

Take these precautions when using these power tool types:

Electric

- Make sure tools are grounded
- If working outdoors only use a outlet with GFI protection
- Use double-insulated tools when possible
- Do not use electric tools in damp or wet locations, and store the tools in a dry place
- Never yank the cord to disconnect it from the receptacle

Hydraulic

- Use approved fire-resistant fluid rated for the most extreme temperatures to which it will be exposed
- Do not exceed the manufacturer's recommended safe operating pressures
- Do not check for leaks using your hands because fluid under pressure may puncture skin

PNEUMATIC

- Always wear eye and hearing protection
- Use a safety clip or retainer to prevent attachments, such as chisels on a chipping hammer, from being unintentionally shot from the barrel
- Fasten air hoses together securely with wire or a locking device

FUEL

- Store and transport fuel only in containers approved for this application
- Shut off the engine and extinguish all open flames before refueling
- When operating equipment in closed areas, be sure there is proper ventilation.

Drill Press

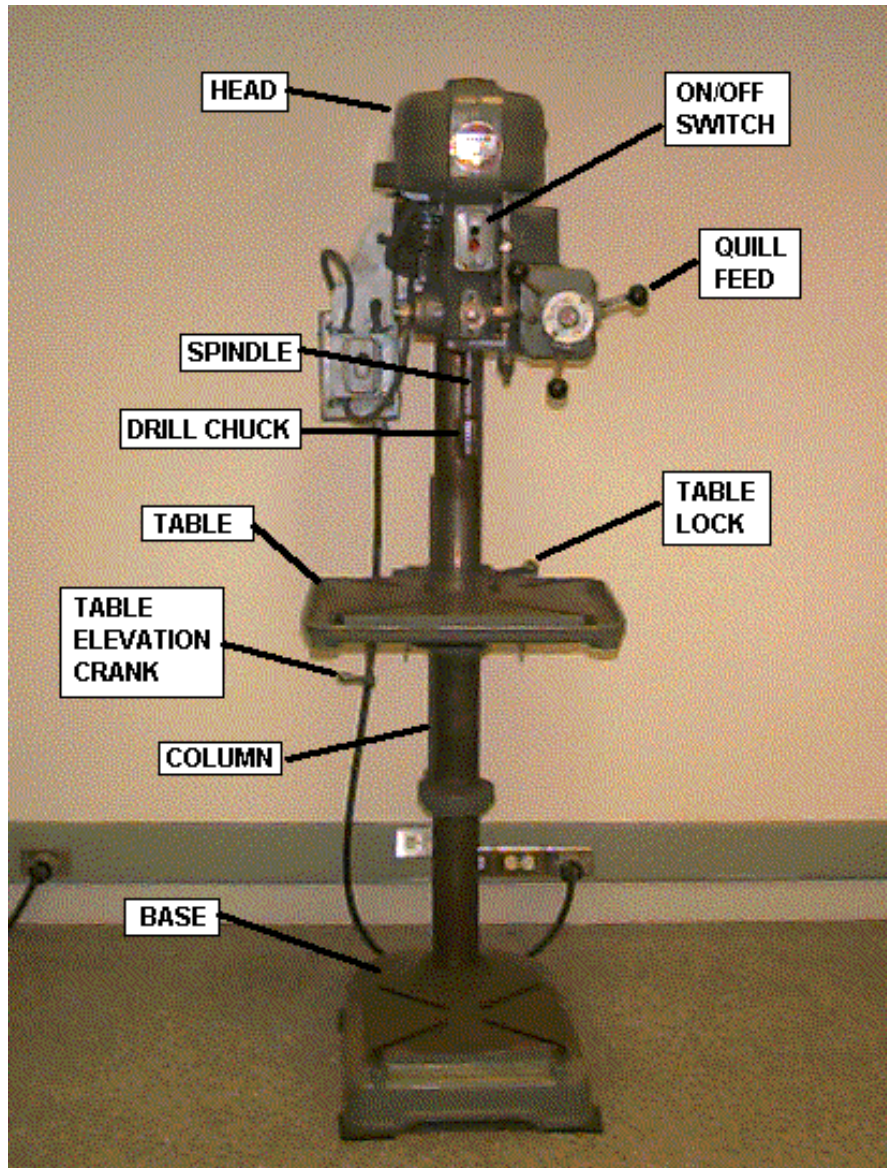

A powered vertical drilling machine in which the rotating bit is pressed to the work by a hand-lever. The work is secured to a table. The spindle speed is changed by selection of a pair of step-pulley grooves. Larger drill bits turn at slower speeds. Lubricant (cutting fluid) can be used to cool and improve cutting.

Drill Press Safety Guidelines Class 4

1. Run drill at correct RPM for diameter of drill bit and material. Ask shop personnel for the correct RPM.
2. **Always** hold work in a vise or clamp to the drill table.
3. Use a correctly ground drill bit for the material being drilled. Shop personnel can help select the correct bit.
4. Use the proper cutting fluid for the material being drilled. Ask the shop staff about the appropriate fluid for the material you are machining.
5. Remove chips with a brush, **never** by hand.
6. Ease up on drilling pressure as the drill starts to break through the bottom of the material.
7. Don't use a dull or cracked drill. Inspect the drill before using.
8. Don't drill with too much pressure.
9. Always try to support part on parallels or a backing board when drilling thru material.
10. **Never** place taper shank tools such as large diameter drills or tapered shank reamers in a drill chuck. Only straight shank tools such as standard drills can be clamped in chucks.
11. Always clean drill shank and/or drill sleeve, and, spindle hole before mounting.
12. Remove taper shank tools from spindle or sleeve with a drill drift and hammer.
13. **Never** try to loosen the drill chuck while the power is on.
14. Lower the drill spindle close to the table when releasing the drill chuck or taper shank drill to reduce the chance of damage should they fall onto the table.
15. **Never clean a machine while it is in motion!!**
16. If the drill binds in a hole, stop the machine and turn the spindle backwards by hand to release the bit.
17. **When drilling a deep hole withdraw the drill bit frequently to clear chips and lubricate the bit.**
18. **Always remove** the drill chuck key or, the drill drift from the spindle **immediately after using it.**
19. Wear safety eye protection while drilling.
20. Let the spindle stop of its own accord after turning the power off. **Never try to stop the spindle with your hand.**
21. Plexiglas and other brittle plastics can be difficult to drill. Ask the shop superintendent for advice on drill and coolant selection when drilling these materials.

BANDSAW

**Horizontal
&
Vertical**

Horizontal & Vertical Bandsaw Safety Instructions

Class 3

1. Keep all guards in place.
2. Adjust the blade to within 1/8" to 1/4" of the stock.
3. Blade guards that are over 1/4" above the work *will lead to accidents and reduces the accuracy of your cut.*
4. Maintain the stock flat on the table.
5. Use extreme care when cutting round stock on the band saw. The round stock may roll into the blade causing an accident.
6. DO NOT INTERRUPT others while using power equipment.
7. Stay focused until the blade has stopped moving.
8. NEVER leave the machine operating while unattended.
9. Keep the work area clean. Scrap material or tools on the floor or bandsaw table will lead to accidents and injuries.
10. If the blade comes out of the guides or breaks, stop the machine immediately by turning off the power. Do not open the access door to the machine until the wheels have come to a complete stop. Have the instructor reposition or install a new blade.
11. Do not reach across or position your hands or fingers in front of or in line with the saw blade.
12. Never back material out of a cut until power has been turned off and the motion of the blade has stopped.
13. ALWAYS use a push bar when sawing regardless of stock size or material.
14. Hold the stock to the sides of the cutting line.
15. Keep your hands and fingers at least 3 inches from the side of the blade. Never cross the blade path.
16. Use 'relief cuts' on tight curves to avoid breaking the blade.

The Horizontal Band Saw

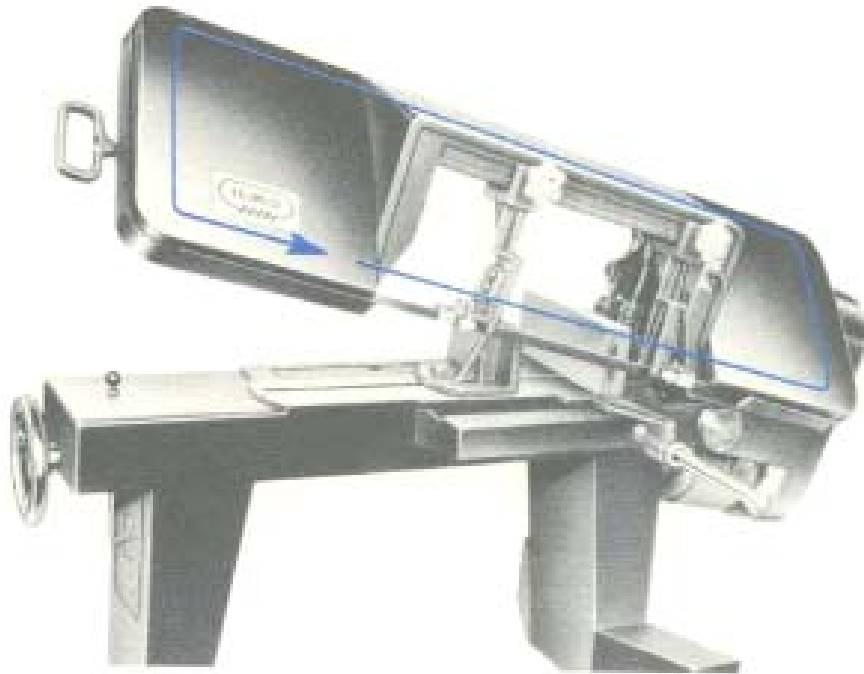
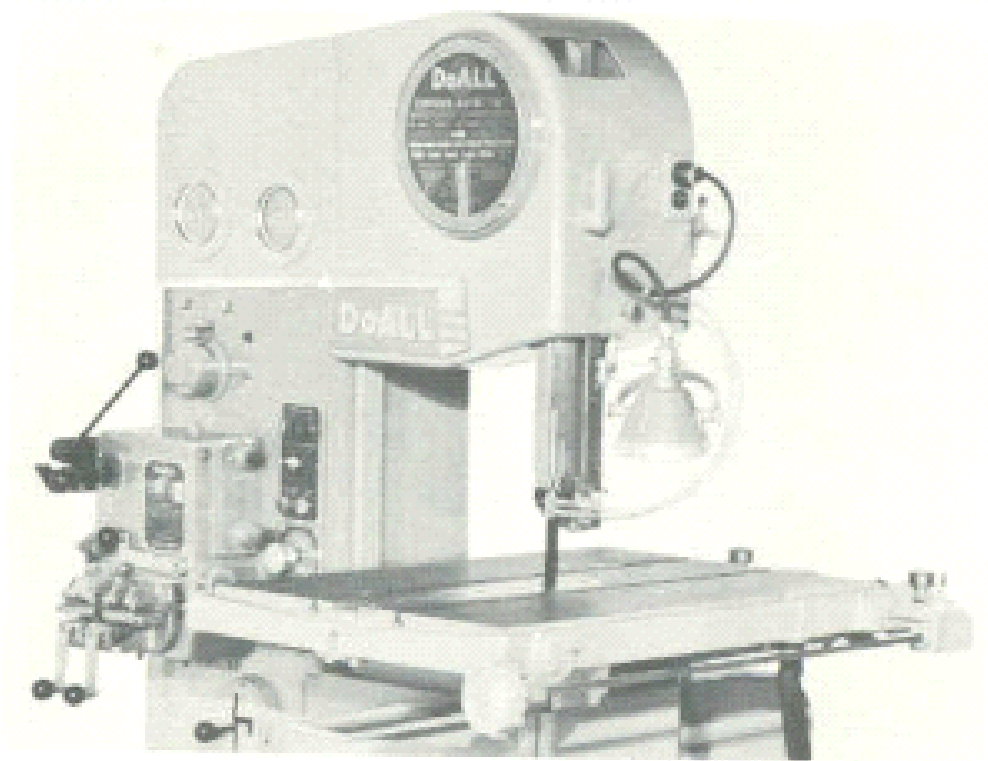

*Fig. 35-2. Metal cutting band saw.
(Kalamazoo Tank & Silo Co.)*

The horizontal bandsaw incorporates a vise to clamp the material while the frame holding the moving bandsaw blade pivots downward allowing the blade to contact and begin cutting the material. The rate of feed is controlled by a hydraulic or spring resistance.

Please read and understand the Safety Rules in this section for both types of bandsaws.

Vertical Band Saw



The Vertical Bandsaw has a moving bandsaw blade fixed in a vertical position while the material to be cut is fed into the blade by the operator's hands.

Advantage of using the Band Saw:

1. Faster Cutting – the long blade moves in only one direction, and being continuous, can be run at much higher speeds as the blade rapidly dissipates the heat generated in cutting.
2. Precision – The blade can be guided more accurately than the blade on the reciprocating saw and can utilize a finer blade for a given piece of material. It is common practice to cut directly to the line when using a band saw.
3. Little Waste – The small cross section of the band saw blade make smaller and fewer chips for a given length or thickness of material. The blades are made from tungsten and molybdenum steel and with tungsten carbide teeth on alloy steel backs. The carbide tip blades are more expensive.

Please read and understand the Safety Rules in this section for both types of bandsaws.

LATHE

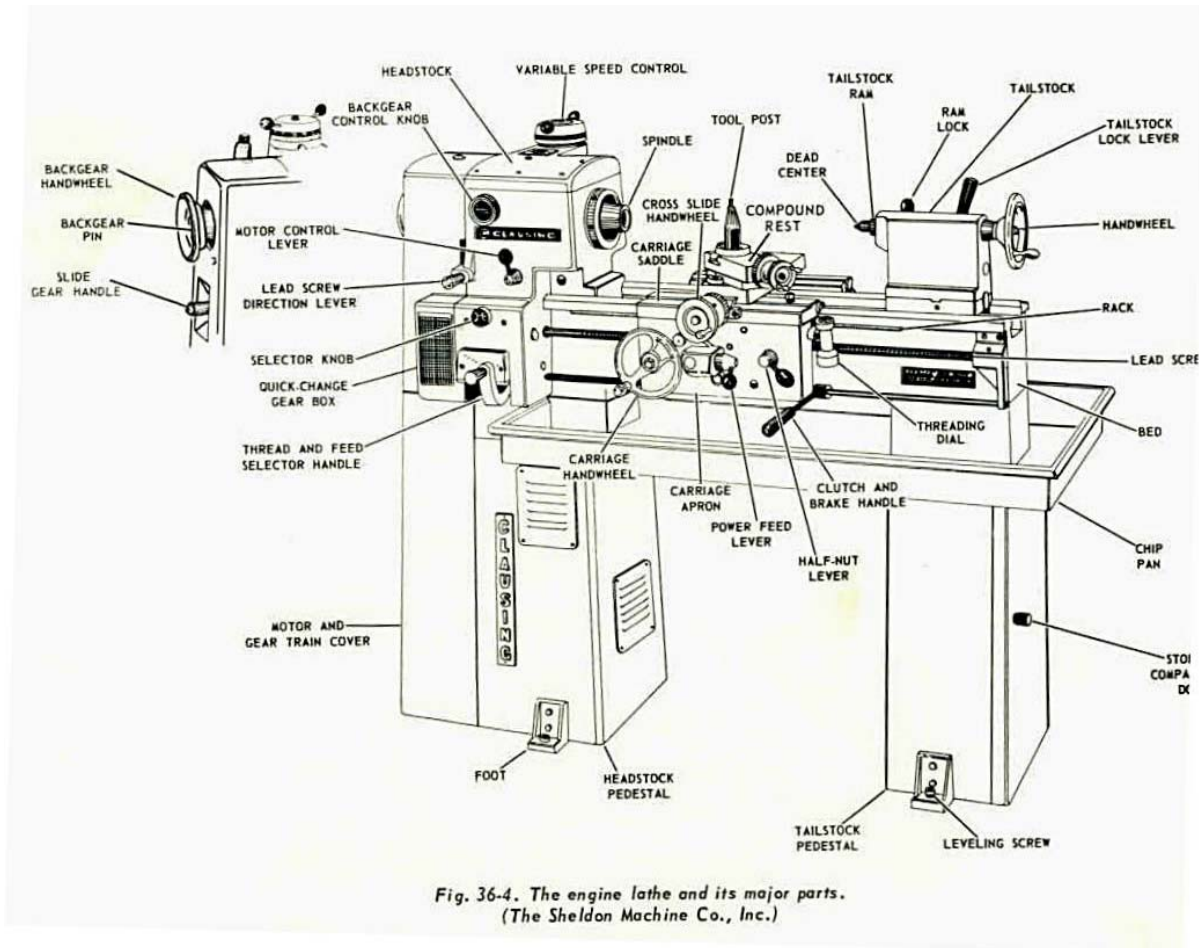

METAL LATHE

A lathe is a machine tool in which the work is held and rotated, while being shaped by a cutting tool that is fed against the work.

LATHE SAFETY Class 5

1. Do not attempt to operate the lathe until you have been checked out on it and are thoroughly familiar with its operation.
2. Dress appropriately. Remove your necktie, sweater, wrist watch and rings. Wear an apron or a properly fitted shop coat. Safety goggles are a must.
3. Clamp all work solidly. Use the correct size tool or work holding device for the job. Get help if you must use heavy chucks or attachments. Do not permit small diameter work to project too far from the chuck without support from the tailstock center
4. Check your work frequently when it is being machined between centers. The work expands as it heats up and could damage the tail center if it overheats.
5. Replace all guards before starting to work. The guards should only be removed to make adjustments, and then with the power turned off at the main electrical panel to prevent the machine from being turned on accidentally. Replace the guards immediately after the adjustments have been made.
6. Return all unnecessary tools to the proper storage area. Remove all other tools from the immediate work area.
7. Turn the chuck or faceplate by hand to be sure there is no binding or danger of the work striking any part of the lathe.
8. Make sure that the chuck, driveplate, or faceplate is securely tightened onto the lathe spindle.
9. When removing the chuck, driveplate, or faceplate **do not use machine power**.
10. When installing the chuck, driveplate, or faceplate **do not use machine power**.
11. Move the tool bit a safe distance from the collet or chuck when inserting or removing work.
12. Don't run the machine faster than the proper cutting speed – consult a speed and feed table to determine the best speed.
13. In setting up the tool holder place it to the **left side of the compound slide** to prevent the compound slide from running into the chuck or spindle attachments.
14. Always clamp the tool bit as short as possible in the tool holder to prevent it from breaking or chattering.
15. Always make sure that the tool bit is sharp and has the proper clearance. Ask for assistance making adjustments.
16. If any filing is done on work revolving in the lathe, file left handed to prevent slipping into the chuck. **Never use a file without a handle.**
17. If work is turned between centers, make sure that proper adjustment is made between centers and that the tailstock is locked in place.
18. If work is being turned between centers and expands due to heat generated from cutting, readjust centers to avoid excessive friction.
19. Do not grasp or touch chips or turnings with your fingers, but get rid of them using a blunt instrument. It is safer to turn off the lathe before clearing chips than to leave it running.
20. Set the tool bit on the centerline of your work to prevent work from climbing over tool or cutting above center and dragging.
21. Don't cut work completely through when turning between centers.
22. **Remove chuck key from chuck immediately after using.**
23. Turn chuck or faceplate through by hand before turning on the power to be sure there is no binding or clearance problem.
24. Stop the machine before taking measurements.

25. Before cleaning the lathe remove tools from the tool post and tailstock.
26. Stop the machine before making adjustments or measurements.
27. Remember that the chips are razor sharp. Do not attempt to remove chips with your fingers. Stop the machine and use pliers to remove them.
28. Be careful not to run the cutting tool into the chuck or dog. Check out any readjustment of work or tool to be sure there is ample clearance between the tool and the chuck or dog, when the tool has been moved left to the farthest point that will be machined.
29. Do not use cotton waste or rags to wipe grease or oil from the work surface unless the machine is stopped. Keep brushes used for cleaning and to apply coolant, clear of work when knurling.
30. If work must be removed from the lathe, or repositioned in the chuck, always move the cutting tool clear of the work or reverse it in the tool post to prevent it from cutting you accidentally.
31. Do not talk to anyone, nor permit anyone to fool around the machine while you are operating it. You are the only one who should turn the machine on or off, or make adjustments to the lathe while you are operating it.
32. Never attempt to run the chuck on or off the spindle by using power. It is also a dangerous practice to stop the lathe by reversing its direction of rotation.
33. You should always be aware of the direction and speed of the carriage or cross-feed before engaging automatic feed.
34. Do not wrap the cord around your hands when cleaning the lead screw. Grip it lightly between the fingers so if it catches on the screw it will slip safely out of your hand.
35. Stop the machine immediately if some odd noise or vibration develops while you are operating it. If you cannot find what is causing the trouble, get your instructor. Under no condition should the machine be operated until the trouble has been found and corrected.
36. Remove all burrs and sharp edges from the piece before removing it from the lathe.
37. Plan your work thoroughly before starting. Have all of the tools that will be needed at hand before commencing work
38. Be careful when you clean the machine. As stated before, chips and shaving are sharp and will cause serious cuts if you attempt to remove them with your hands. Use a cleaning brush, **NOT A DUST BRUSH**, for the job. **NEVER USE THE AIR HOSE**. The flying chips may injure someone.

PREPARING THE LATHE FOR OPERATION

1. Clean and lubricate the lathe. Use the lubricants specified by the manufacturer.
2. Turn the spindle by hand to make sure it is not locked in back gear. Set the drive mechanism to the desired speed and feed.
3. Place all guards in position.
4. Move the carriage along the ways; there should be no binding.
5. Inspect the cross-feed and compound rest slides. Adjust the gibs if there is too much play. Do not permit excessive overhang of the compound rest.
6. Inspect the tailstock if it is to be used for any portion of the operation. Check it for alignment and use a smooth dead center.
7. Place the proper work holding attachment on the headstock spindle. Clean the threads and apply a drop of oil.
8. Sharpen the cutter bit. Clamp it in the appropriate tool holder and mount it in the tool post.

HOW TO CLEAN THE LATHE

1. A lathe should be cleaned after each work period. Remove chips with a paint brush – **NOT YOUR HAND.**
2. Wipe all painted surfaces with a soft cloth.
3. To complete the job, move the tailstock to the extreme right and use a soft cloth to wipe the remaining oil, chips and dirt from the machined surfaces. **DO NOT USE COMPRESSED AIR TO REMOVE THE CHIPS.** The flying chips are dangerous.
4. The lead screw needs an occasional cleaning too. This may be done by adjusting the lathe to rotate at a slow speed and using a piece of cord. Permit the cord to feed along the threads. **DO NOT WRAP THE CORD AROUND YOUR HAND because THE CORD MIGHT CATCH ON THE LEAD SCREW AD CAUSE SERIOUS INJURY!**

LATHE SIZE

Lathe size is determined by the SWING and BED LENGTH. The swing indicates the largest diameter of work which can be turned. The bed length is the entire length of the ways, and should not be mistaken for the maximum length of metal piece that can be turned.

MAJOR PARTS OF THE LATHE

Each of the lathe parts fall into one of three functional categories:

1. DRIVING THE LATHE
2. HOLDING AND ROTATING THE WORK
3. HOLDING AND MOVING THE CUTTING TOOL

LATHE BED

The lathe bed is the foundation or base to which the other parts of the lathe are fitted. Carefully machined ways on top of the lathe bed support and provide for precise alignment of the headstock and tailstock.

HEADSTOCK

The headstock contains the SPINDLE to which the various work holding attachments are fitted. The spindle is hollow with the front end tapered internally to receive tools and attachments with taper shanks. The hole permits long stock to be turned and allows a KNOWCKOUT BAR to be used to remove taper shank tools.

The spindle is usually fitted with either a tapered nose or a threaded nose. Also found in the headstock is the SPEED CONTROL MECHANISM. Power supplied by an electric motor is transmitted to the spindle by moving the belts to positions on the pulleys or by changing the gear ratio.

Slower speeds on belt driven lathes are obtained by engaging the BACK GEARS. The large gear (BULL GEAR) is keyed to the spindle and is locked to the pulley with the BULL GEAR LOCK PIN. The back gears can be engaged by disconnecting the bull gear from the step pulley by releasing the bull gear lock pin. DO NOT ENGAGE THE BACK GEARS WHILE THE SPINDLE IS ROTATING.

TAILSTOCK

The tailstock can be adjusted along the lathe ways to accommodate different lengths of work. It mounts the “dead” center that supports the outer end of the work, and can be fitted with cutting tools for drilling, reaming and threading. The unit is clamped to the ways by tightening the CLAMP BOLT NUT. The spindle is positioned by rotating the HANDWHEEL and is locked in position with the BINDING LEVER.

CARRIAGE

The carriage includes the SADDLE, APRON, CROSS AND LONGITUDINAL FEED, SCREW CUTTING MECHANISM, COMPOUND REST and TOOL POST. The cutting tool is supported and its actions controlled by the carriage which is moved along the ways by hand or power feed. The power feed mechanism is located in the apron. A friction clutch controls longitudinal and cross power feeds. Half-nuts are engaged for thread cutting.

FEED MECHANISM

The feed mechanism transmits power through a train of gears to the QUICK CHANGE GEAR BOX, which regulates the amount of tool movement per revolution of the spindle. The feed mechanism also contains gears for reversing tool travel. Lettering on the INDEX PLATE tells how to position the levers for various thread cutting and feed combinations.

The LEAD SCREW transmits the power to the carriage through a gearing and clutch arrangement in the apron. The FEED CHANGE LEVERS on the apron control the operation of power feeds and, when placed in neutral, permit half-nuts to be engaged for threading operations.

WOOD LATHE

Note:

Wood lathe requires specific on the job training prior to use.



Wood Lathe

Description

Lathes are great to work with, you can create so many things, table legs, baseball bats, staircase rungs, just to name a few. But it can be a dangerous tool if you are inexperienced, not trained properly, or careless. You can be hurt severely or even killed. Proper safety training is very important. Safe, effective use of a wood lathe requires study and knowledge of procedures for using this tool.

NOTE:

Only SPECIALLY trained students can operate the wood lathe.

SAFETY

1. Always wear safety goggles or safety glasses that include side protectors. Use a full faceshield or full lathe guard in addition to safety glasses.
2. Fine particles from a grinder and wood dust are harmful to your respiratory system. Use a dust mask, or dust collection system or a combination of these to deal with this serious issue. Be especially mindful of dust from many exotic woods, glued or composite woods or any wood from which you notice a skin or respiratory reaction.
3. Wear hearing protection during extended periods of time.
4. Turn the lathe “off” before adjusting the tool rest or tool rest base (banjo).
5. Remove chuck keys, adjusting wrenches and knockout bars. Form a habit of checking for these before turning on the lathe.

6. Tie back long hair, do not wear gloves, and avoid loose clothing, jewelry or any dangling objects that may catch on rotating parts or accessories.
7. Make certain that the belt guard or cover is in place.
8. Check that all locking devices on the tailstock and tool rest assembly (rest and base) are tight before operating the lathe.
9. Make sure the blank is securely fastened.
10. Rotate your workpiece by hand to make sure it clears the toolrest and bed before turning the lathe “on”. Be certain that the workpiece turns freely and is firmly mounted. A handwheel on the headstock simplifies this process of spinning the lathe by hand before turning on the switch.
11. Be aware of what turners call the “red zone” or “firing zone.” This is the area directly behind and in front of the workpiece—the areas most likely for a piece to travel as it comes off the lathe. A good safety habit is to step out of this zone when turning on the lathe, keeping your hand on the switch in case you need to turn the machine off. When observing someone else turn, stay out of this zone.
12. ALWAYS CHECK THE SPEED OF THE LATHE BEFORE TURNING IT ON. Use slower speeds for larger diameters or rough pieces, and higher speeds for smaller diameters and pieces that are balanced. Always start a piece at a slower speed until the workpiece is balanced. If the lathe is shaking or vibrating, lower the speed. If the workpiece vibrates, always stop the machine to check the reason. As a starting point, consult your operator’s manual for recommended speeds for a particular lathe. Make sure the lathe speed is compatible with the size of the blank.
13. Exercise extra caution when using stock with cracks, splits, checks, bark pockets, knots, irregular shapes, or protuberances. Beginners should avoid these types of stock until they have greater knowledge of working such wood.
14. Hold turning tools securely on the toolrest, holding the tool in a controlled but comfortable manner. Always contact the tool rest with the tool before contacting the wood.
15. When running a lathe in reverse, it is possible for a chuck or faceplate to unscrew unless it is securely tightened or locked on the lathe spindle.
16. All glued work must be fully set before being turned.
17. Always remove the tool rest before sanding, finishing or polishing operations.

Basic Parts

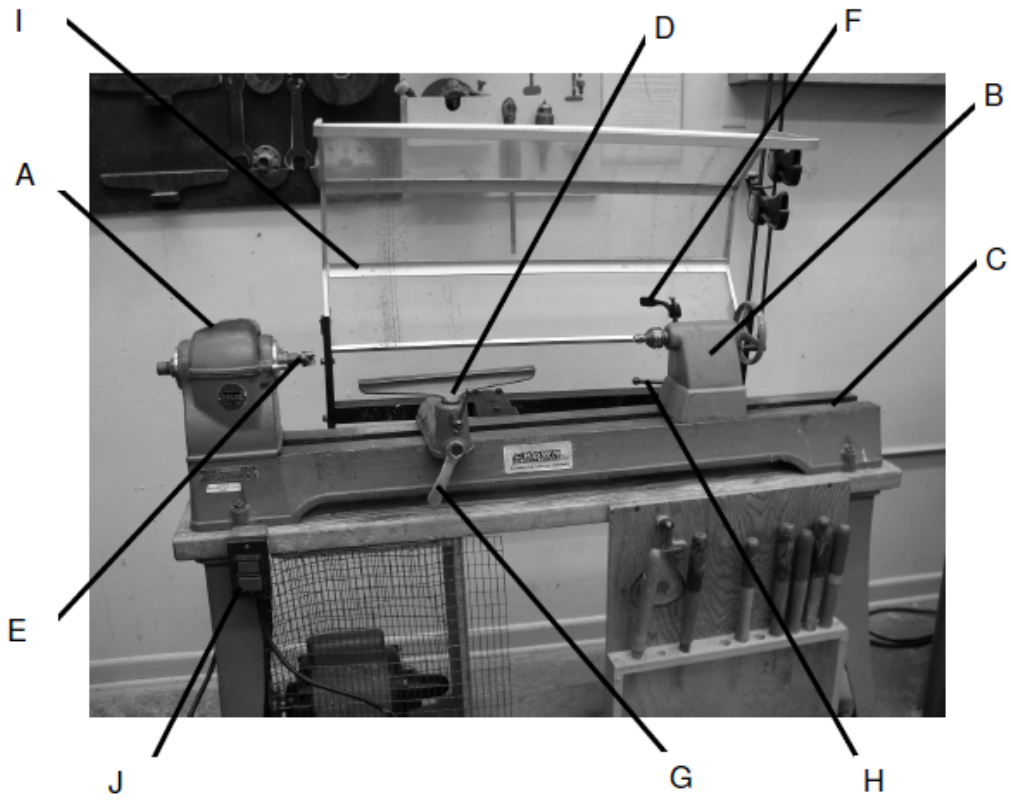

A. Headstock

B. Tailstock

C. Bed

D. Tool Rest

E. Headstock Spindle

F. Tailstock Spindle Lock Lever

G. Tool Rest Lock Lever

H. Tailstock Lock Lever

I. Guard

J. On-Off Switch

K. Cone Pulley Speed Control

L. Variable Speed Control for Variable speed lathe



K



L

Lathe Tools:

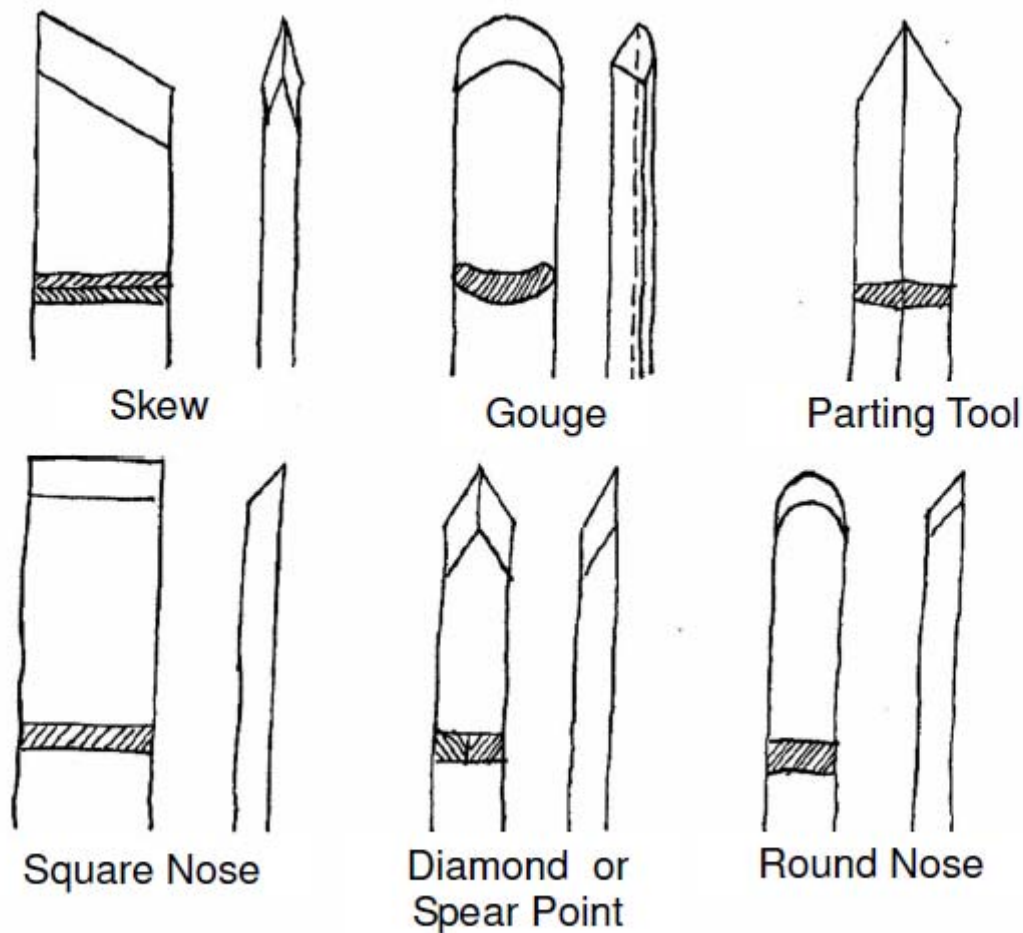

Operation Procedure

Spindle Turning: Turning stock that needs to be supported at both ends by the spur center and cup center. Typically you would use spindle turning when you are making a project that is long like a bat or chair leg.

1. Locate the center on each end of the piece of wood by drawing diagonals across the corners.
2. Make 1/8" deep cuts on the diagonal lines of one end of the project. This will be the end that the spur center will be attached to.
3. Drive a spur center into the cuts with the center pin in the center of the project with a wooden mallet.
4. Snap the cup center into the tail stock to lock it into place.
5. Snap the spur center and project into the head stock.
6. Move the tail stock to within 1 inch of the project and lock it to the lathe bed.
7. Move the cup center into the center of the project using the tail stock hand wheel.

Tighten down the tail stock spindle with the spindle lock lever.

8. Install and adjust the tool rest 1/8" away from the edge of the project and 1/2" below the center of the project. Tighten down the tool rest.

9. Turn the project by hand to check for proper clearance.

10. Adjust the lathe to its slowest speed.

- For the cone pulley this would be the largest pulley on the headstock and the smallest pulley on the motor.

- For the variable speed lathe, make sure the motor is turned on before you adjust the speed handle.

11. Always wear eye protection when operating the lathe.

12. Use a gouge chisel for rough turning and scraper or skew for finish turning.

13. Place chisels on the tool rest with one hand on the butt of the chisel and one on the blade. Firmly hold the chisel down and against the tool rest. The point of the chisel should be even with the center of the project.

14. Once you have rounded the project and are ready to shape it, increase the spindle speed to medium.

15. After you are done turning and are ready to sand the project, remove the tool rest.

This is an important safety practice and will help prevent things from getting caught between the work and the tool rest.

16. Sanding will go faster if you increase the spindle speed to high.

17. When you have finished, loosen the tailstock locking lever and the hand wheel to remove your project from the lathe.

18. If you need to remove the spur center from the head stock, insert the knock out bar into the hollow headstock spindle and tap the end back end of the spur center until it loosens up and can be removed.

Operation Procedure

Faceplate Turning: Turning stock that has been mounted to a faceplate and screwed onto the headstock. Faceplate turning most commonly used when the face of a project needs to be turned like a plate or bowl.

1. If you have glued pieces of wood together to make your project, make sure the joints are tight and the glue has dried for at least 2 hours.

2. Mount the faceplate to your project with woodscrews. You may consider gluing a scrap piece of wood to your project to attach the face plate to so you don't have screw holes in your project.

3. Cut out the rough diameter of your project with the band saw.

4. Screw the faceplate onto the headstock spindle and tighten with wrenches.

5. Adjust the tool rest height 1/2" below the center of your project and 1/8" away from the edge.

6. Turn the project by hand to check for clearance. Make sure that the project turns freely and does not hit the tool rest.

7. Adjust the lathe to its slowest speed.

- For the cone pulley lathe, this would be the largest pulley on the headstock and the smallest pulley on the motor.

- For the variable speed lathe, make sure the lathe is turned on before you

adjust the speed .

8. Always stand to the far left of the lathe when you first turn it on so you are out of the way if the project comes off.

9. Always wear safety glasses.

10. Use a scraper chisel to round the outside of the project first to get the project perfectly balanced. After the outside is rounded, turn the face or inside of the project

11. Use a square or round nose chisel when shaping the project.

12. Place chisels on the tool rest with one hand on the butt of the chisel and one on the blade. Hold the chisel firmly on top of and against the tool rest. The point of the chisel should be even with the center of the project.

MANUAL MILL

**Horizontal
&
Vertical**

MILL SAFETY RULES Class 5

1. Do not attempt to operate the machine until you are thoroughly familiar with it. When in doubt, secure additional instructions.
2. Work must be clamped securely in a vise and vise clamped tightly to the table, or, work must be clamped securely to the table.
3. Wear appropriate safety glasses.
4. Ensure that the cutter is mounted securely before taking a cut.
5. Remove the collet tightening wrench immediately after using it.
6. Hold milling cutters with a cloth to avoid being cut when handling them.
7. Move table as far as possible from cutter while setting up work to avoid injuring your hands.
8. Mill the largest surface first.
9. Keep hands, brushes and rags away from the revolving milling cutter.
10. Use a vacuum, brush or rake to remove cuttings only after the cutters have stopped moving. .
11. Always use cutters which are sharp and in good condition.
12. Keep working surface clear of scraps, tools and materials.
13. Keep floor around the milling machine free of oil and grease.
14. Use lifting equipment when appropriate to move heavy work to or from milling machines.
15. Do not take climb milling cuts on the shop's mills unless instructed to do so.
16. Make sure cutter is rotating in the proper direction before cutting material.
17. Before running machine the spindle should be rotated by hand to make sure it is clear for cutting.
18. Make sure the power is off before changing cutters. Do not allow anyone to be near the power switch.
19. Always use the proper cutting fluid for the material being cut.
20. Never run the machine faster than the correct cutting speed.
21. Make sure that the machine is fully stopped before taking any measurements.
22. Don't place anything on the milling machine table such as wrenches, hammers, or tools.

23. Always stay at the machine while it is running.
24. Don't take too heavy a cut or use too rapid a feed.
25. If at all feasible rig a guard or shield to prevent chips from hitting other people.
26. Use the milling machine spindle brake to stop the spindle after the power has been turned off.
27. Before cleaning the mill remove cutting tools from the spindle to avoid cutting yourself.
28. Wear appropriate clothing and eye protection.
29. Get help to move any heavy attachment like the vise, dividing head, rotary table, etc.
30. Use care to protect your hands from sharp tools.
31. Use a small brush or vacuum to remove chips – NEVER BRUSH WITH YOUR HAND! Stop the machine before attempting to remove chips.
32. Never reach over or near the rotating cutter.
33. Do not talk to anyone while operating the machine, nor allow anyone to turn on your machine for you.
34. No adjustments should be made while the cutter is rotating. Stop it before making measurements, removing chips, etc.
35. Be thoroughly familiar with the STOP lever.
36. Put all oily rags used to wipe down the machine in a metal container that can be closed tightly.
37. Do not fool around while operating the mill. Keep your mind on your job and be ready for any emergency.

Horizontal Mill

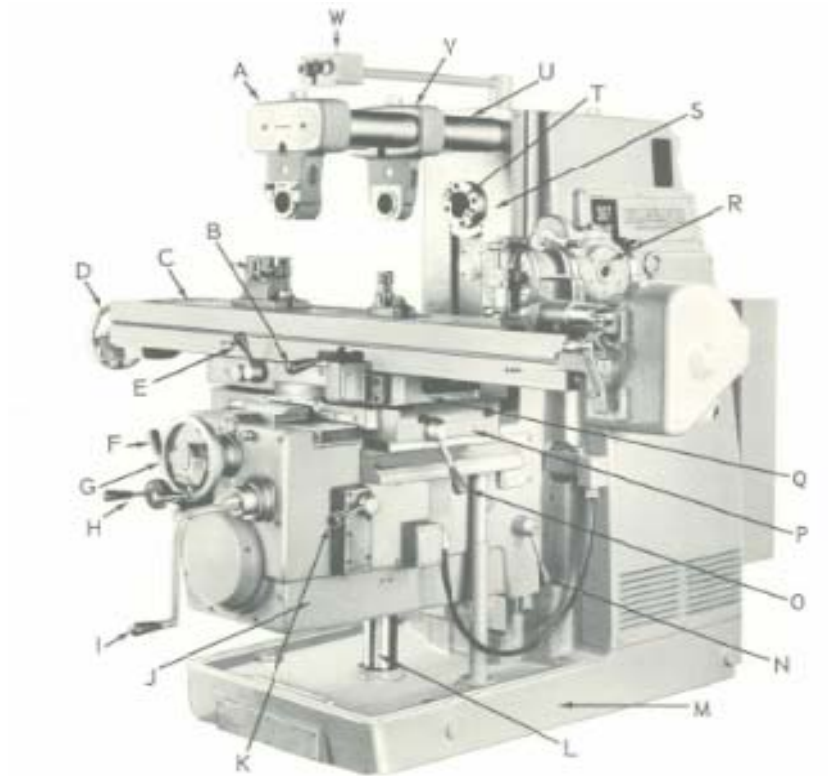
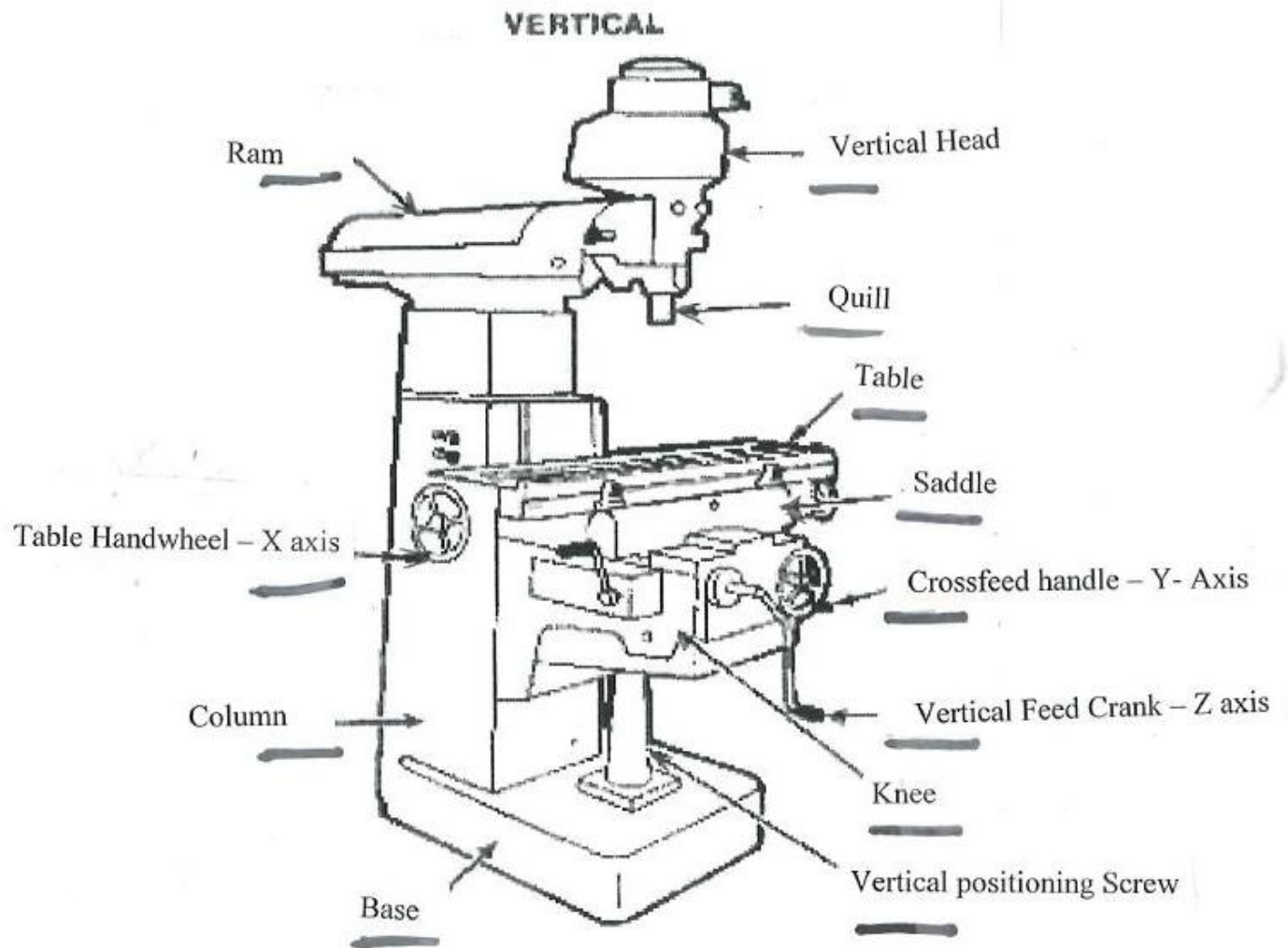

Fig. 20-3. Parts of the milling machine: A-Arbor support, B-Table lead lever, C-Table, D-Table handwheel, E-Table clamp lever, F-Saddle power lead lever, G-Saddle handwheel, H-Knee power lead lever, I-Knee handwheel, J-Knee, K-Rapid traverse lever, L-Telescopic coolant return and elevating screw, M-Base, N-Knee clamp lever, O-Saddle clamp lever, P-Saddle, Q-Saddle plate, R-Universal dividing head, S-Column, T-Spindle, U-Dividers, V-Knee arbor support, W-Spindle start-stop and motor switch (the arm engages the clutch).
(Keeney & Trecker Corp.)

This Mill has a spindle on a horizontal axis unlike the Vertical Mill. The cutters are generally keyed to an arbor and driven by the spindle. A very robust and sturdy machine, the Horizontal Mill is chosen over the Vertical Mill when large quantities of material has to be removed by the cutters or there is less need for accuracy. A substantial vise is required or very secure clamping techniques to secure the material to the table.

Vertical Mill



General Mill Information

COLUMN AND KNEE TYPE MILLING MACHINE

The column knee type milling machine is so named because the components that provide movement to the work consists of a COLUMN that supports and guides the KNEE in vertical movement. The knee supports the mechanism for obtaining cross traverse and longitudinal table movements: VERTICAL, CROSS, & LONGITUDINAL, all of which are controlled entirely by hand levers.

All milling operations fall into two main categories:

1. FACE MILLING – The surface machined is parallel with the face of the cutter. Large flat surfaces are machined by this method.
2. PERIPHERAL MILLING – The surface being machined is parallel with the periphery of the cutter.

Milling cutters come in a large number of stock shapes, sizes, and kinds to meet many requirements. There are two general types:

1. SOLID CUTTER – The shank and body are made in one piece.
2. INSERTED TOOTH CUTTER – The teeth are made of special cutting material and are brazed or clamped into place. Teeth can be replaced.

Consult your instructor for the type of cutter needed.

There are two distinct cutting methods in milling operations:

1. CONVENTIONAL or UP-MILLING – The work is fed into the rotation of the cutter. The chip is at minimum thickness at the start of the cut and is so slight that the cutter has a tendency to slide until sufficient pressure is built up to make it bite into the work.
2. CLIMB or DOWN-MILLING – The work moves in the same direction as the rotation of the cutter. Full engagement of the tooth is instantaneous. The sliding action of conventional milling is eliminated resulting in a better finish and a longer life.

Climb milling is not recommended on light milling machines because lack of rigidity and light support offsets any advantages of the technique.

Care of Milling Cutters and Cutter Holding & Driving Devices

1. Support the cutter properly and hold the work rigid
2. Use the correct cutting speed and feed
3. An ample supply of cutting fluid is essential
4. Use the correct cutter for the job
5. Store cutters in individual compartments or on wooden pegs
6. Clean cutters before storing
7. Never hammer a cutter on the arbor. Examine the arbor for burrs or nicks if the cutter does not slip on easily
8. Use sharp cutters

9. End mills are held in collets or special holders while drill bits are held in chucks that install into the spindle.

To maintain accuracy during the machining operation it is necessary to prevent damage to the cutter holding and driving devices:

1. Keep the taper of the arbor free of nicks
2. Clean and lubricate the bearing sleeve and arbor support bearing before use
3. Clean the spacing collars before placing them on the arbor, otherwise cutter run-out will occur
4. Store arbors separately and in a vertical position
5. Never loosen or tighten the arbor nut unless the arbor support is locked in place
6. Use a wrench of the correct type and size
7. Do not tighten the arbor nut by striking the wrench with a hammer or mallet. This may crack the nut or distort the threads
8. To remove an arbor or adapter from the machine:
 - a. Loosen the nut on the draw-in bar a few turns. DO NOT remove it from the arbor completely
 - b. Tap the draw-in bar head with a lead hammer to loosen the arbor from the spindle
 - c. Hold the loosened arbor with one hand and unscrew the draw-bar with the other
 - d. Remove the arbor from the spindle, clean and store it

Cutting Speeds and Feeds, Fluids

The time required to complete a milling operation and the quality of the finish of the machined surface is almost completely governed by the CUTTING SPEED and FEED of the cutter.

Cutting Speed refers to the distance, measure in feet, a point (tooth) on the circumference moves in one minute. It is expressed in terms of FEET PER MINUTE (FPM) and is directly dependent on the REVOLUTIONS PER MINUTE (RPM) of the cutter.

Feed is the rate the work moves into the cutter and is given as FEED PER TOOTH PER REVOLUTION (FTR). The selection of the proper feed is probably the most difficult thing for the machinist to determine. In view of the many variables; width of cut, depth of cut, condition of the machine and cutter, etc., feed should be as coarse as possible and consistent with the desired finish.

Consult the mill manual or wall chart for the speeds and feeds required for various materials.

Cutting Fluids serve several purposes. They carry away the heat generated during the machining operation, act as a lubricant and prevent the chips from sticking or fusing to the cutter teeth, and flush away chips. The lubricating qualities also influence the quality of the finish of the machined surface.

UNTIL YOU BECOME PROFICIENT IN THE USE OF THE MILL, CONSULT YOUR INSTRUCTOR OR SHOP PERSONNEL BEFORE STARTING ANY MACHINING!

More information can be found in the reference book “Modern Metalworking”

BENCH GRINDERS

Grinder Safety Instructions

1. Always use proper eye protection.
2. Special training is required before using the surface grinder. Ask shop staff to demonstrate proper use of this tool.
3. Abrasive wheel machinery shall not be operated without the appropriate guards in place.
4. Tool rests on bench or pedestal grinders shall be set no more than 1/16 inch from the wheel.
5. Never use a wheel that has been dropped or received a heavy blow, even though there may be no apparent damage. Such wheels may be weakened or unbalanced enough to fly apart on startup.
6. Stand to one side when starting a grinding machine. Damaged wheels will sometimes fly apart, and this is most likely to happen when the machine is being started. Stand to the side so that you will not be in-line with the debris.
7. Do not grind on side of wheel unless wheel is specifically designed for such use.
8. Do not use excessive pressure while grinding. On surface grinder do not exceed .0005 inch down-feed at any time.
9. Report to the area supervisor immediately any cracked, broken or otherwise defective wheels.
10. Have the area supervisor mount and balance new wheels.
11. Keep the grinding wheel dressed. Dressing a small amount frequently is better than having to dress a lot later and will allow the wheel to cut faster, cooler and with a better surface finish. Dressing is cleaning and smoothing the surface of the grinding wheel.
12. Hold work securely while grinding, use the tool rest to support the work when off-hand grinding on bench or pedestal grinders.
13. Do not grind aluminum. Aluminum dust is explosive. Check with shop staff for safety instructions if aluminum must be ground.
14. If a magnetic chuck is being used, on the surface grinder, make sure it is holding the work securely before starting to grind.
15. Move the work back and forth across the face of the wheel. Even wear will result and prevent the wheel from becoming grooved.
16. Do not attempt to use the grinder unless the guards are in place.
17. Keep your hands clear of the rotating grinding wheel. It is a cutting tool and can cause serious injuries.

18. Never force the work into the grinding wheel.
19. Always stop the machine before making adjustments or measurements.

Grinders

The name grinder is commonly used to refer to a unit consisting of a motor with a coarse wheel on one end and a finer wheel on the other. Sometimes a wire brush is installed. When mounted on a bench, it is known as a “Bench Grinder”, on a pedestal a “Pedestal Grinder”.

Other grinding tools are available such as the hand-held angle grinder or die grinder for smaller or specific jobs.

Always observe safety precautions related to rotating wheel which produces flying particles.

Consult Shop Staff before attempting to grind lathe tools or drill bits.

Grinding is the operation that removes material by rotating an abrasive wheel against the work. It is often used for sharpening tools, removing material that is too hard to be machined by any other method, or when fine surface finishes and close tolerances are required.

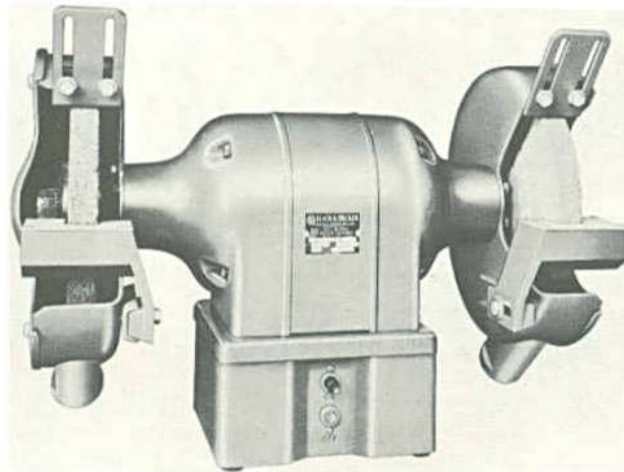

Fig. 33-2. The bench grinder. Eye shields have not been mounted.
(Black & Decker Mfg. Co.)

Bench Grinder

The familiar bench grinders are the simplest and most widely used grinding machines. The type of grinding which they perform is called OFFHAND GRINDING; that is, work that does not require great accuracy of size or shape is held in the hands and manipulated until ground to the desired shape. The bench grinder can be seen in the photo on the previous page, it is fitted to a bench or table. The grinding wheels mount directly onto the motor shaft; one is for coarse, or rough grinding and the other is fine for finishing grinding.

The bench grinder can be dangerous if not used properly.

1. It must never be used unless fitted with guards and safety glass eye shields. **Even then, it is advisable to wear goggles.**
2. A TOOL REST is provided to support the work while grinding. It is recommended that the rests be adjusted to within 1/16 in. of the wheels. This will prevent the work from being wedged between the rest and the wheel. Turn the wheel by hand after adjusting the rest to be sure there is sufficient clearance.
3. The grinding wheel can be another source of danger and should be examined frequently for eccentricity and soundness. A new wheel can be tested by suspending it on a string or wire and tapping the side of the wheel with a light metal rod. A solid wheel will give off clear ringing sound. **A wheel which does not give off such a sound must be assumed to be cracked and should be destroyed. Under no condition should it be used.**
4. Because it is not possible to check the wheels by this manner each time the grinder is used, it is considered safe practice never to stand in front of a grinder when it is first turned on.
5. To keep the grinding wheel true and balanced, we use a WHEEL DRESSER. The wheel dresser should be used to bring abrasive wheels back to round and remove the glaze. The dresser is supported on the tool rest and is held firmly against the wheel with both hands. It is moved back and forth across the surface.

Disc and Belt Sander

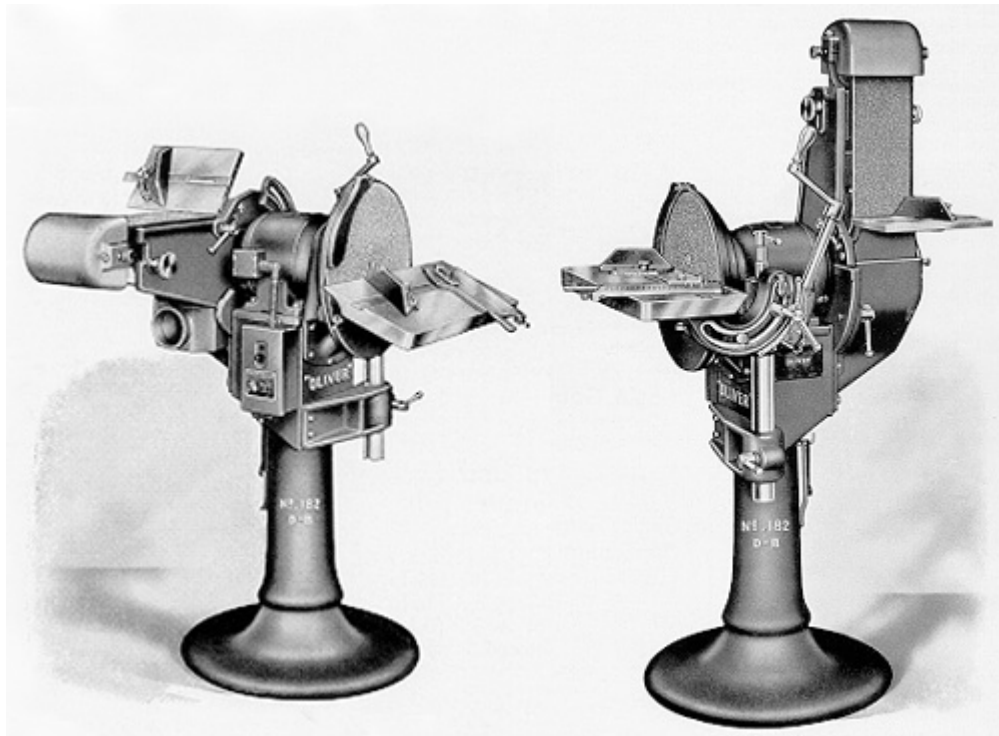

Disc and Belt Sander Safety Guidelines

1. Do not operate sanders without the guards in place.
2. On the disc sander always use the downward motion side of the disc to sand. Never the upward motion side as this can throw your part upwards with tremendous force. Always attempt to place your work against the rest on the disc and belt sanders.
3. On the horizontal belt sander, always sand, so that the belt motion is away from you.
4. Do not operate machines with torn or ripped belts or disks.
5. **Do not sand any material that will give off a dangerous dust. Such materials as beryllium or copper beryllium alloys must not be sanded or filed. Asbestos must not be sanded. Asbestos is an ingredient of brake shoes and pads.**

Disc Sanders generally use a stick-on disc of the desired grit. A worktable is used to rest the material upon. Care must be used in positioning the contact point of the material on the disc to keep flying particles from your eyes. The worktable should be adjusted 1/16" from the disc to prevent trapping the work between the table and the disc.

Belt Sanders make use of a continuous abrasive covered belt operating on flat pulleys and backed by a flat plate allowing the work to be pressed into the belt therefore removing material uniformly.

TABLE SAW



TABLE SAW SAFETY GUIDELINES

1. Use all guards except when blade is covered by the work
2. Special training is required before using the table saw. You may not operate it without permission from the shop supervisor.
3. Stand to one side, never directly in line with, of work being fed through the saw.
4. Use the proper blade for the material and type of cut. Do not use a rip blade for cross cutting, or, a crosscut blade for rip sawing. Do not use a plywood blade for anything but plywood.
5. Inspect the blade before using it, to make sure it is the proper blade and is sharp and free from cracks.
6. Never allow your fingers to get near the blade when sawing. Use a pusher stick to rip narrow pieces of stock. Don't use pusher stick to remove scrap. For scrap removal, shut off machine and wait until blade stops, then remove scraps.
7. Appropriate guards must be in place at all times. Never remove the guard. Ask one of the shop personnel for help if you think the guard is in the way.
8. If the piece of material you are cutting is large, get someone to assist in tailing-off for you. Never try to do it alone. Tailing off refers to supporting a large work-piece by supporting it underneath with your hands.
9. If you are tailing-off for someone else let them guide the work through the saw. You should just support the work without influencing the cut.
10. Never reach over the saw to obtain something from the other side.
11. When shutting off the power, never attempt to stop the saw quickly by shoving anything against the blade. Make sure the saw has stopped before leaving it.
12. Never make any adjustments to the saw while it is running. Turn off the power and make sure the saw is completely stopped before attempting to adjust it.
13. Do not allow material to collect on or around the saw table. Sweep up sawdust and material scraps regularly while working to minimize chances of slipping or stumbling.
14. Make sure that you clean up thoroughly around the saw before leaving the area. If you don't you could be the cause of someone else having an accident.
15. The circular blade of the table saw should be set to 1/8 inch above the work.
16. Keep blades sharp and set for clean cuts
17. Cupped boards should rest on the table with the concave side down
18. Do not force saw to stall. A sharp blade running at full speed will do better work
19. The blade should not project more than 1/8" above the work.
20. Let waste pieces fall off table or stop the saw to remove them. Never reach over or near the blade while it is running
21. Always use a guide to cut by; never saw freehand

22. Use stop blocks for clearance and never the rip fence when cutting to length
23. Always make adjustments with the machine stopped
24. Plan your work before starting the machine
25. Never talk to an operator when machine is running
26. Always use a push stick for ripping narrow pieces
27. The operator should have firm footing. There are nonskid preparations available.
28. No person should be in direct line with the saw blade
29. Never work alone! Always have at least one more person in the room

Operation of Circular Saw – Table Type

The circular saw is used to cut stock to length and width and cut rabbets, grooves, dadoes, and tenons.

Uses:

1. Dado heads are used to cut tenons, dadoes, grooves and rabbets.
2. Tenoning attachment is used to cut tenons without the use of dado heads.
3. Molding heads are used to cut moldings.
4. Length gauges are attached to the miter gauge and are used when cutting several pieces to the same length.
5. Stop block is attached to the rip fence and is used when several pieces are to be cut the same length.
6. A sanding disk is used to sand convex curves and edges of stock.

Principal Parts and Function of Each:

1. BASE, supports the table
2. TABLE, made of cast iron or pressed steel, supports the miter gauge, rip fence, attachments and stock to be cut
3. MITER GAUGE, made of cast iron or aluminum, used as a guide for crosscutting stock
4. RIP FENCE, made of cast iron or pressed steel, used as a guide for crosscutting stock
5. TILTING WHEEL, made of cast iron, used to tilt the saw blade or tilt the table, depending on the type of saw
6. HAND WHEEL, is turned to regulate height of saw
7. SAWBLADE cuts the stock. Saw blade should be made of high grade steel
8. ARBOR, a round shaft to which the saw blade is fastened, is made of high grade steel
9. GUARDS, made of plastic, cast iron or aluminum, protect the operator from injury from the saw blade
10. SPLITTER, made of sheet steel, keeps stock from binding against the saw while cut is being made
11. MOTOR, provides the power.

Using the Circular Saw:

- Stock, with nails, grit, etc., should not be cut.

Crosscutting or squaring an end:

1. Use either a crosscut or combination blade and adjust the height of the saw blade so that it is about 1/8" above the stock to be cut.
2. Set the miter gauge at right angles with the saw blade. Usually a graduated scale will indicate this agreed position or it may be checked with a framing square.
3. Use the saw guard and splitter. The rip fence must be moved clear of the work to prevent binding and "kick-backs."
4. One edge of the work to be cut must be straight. Keep the straight edge against the face of the miter gauge and move the stock to cutting position. Hold the stock firmly against the face of the miter gauge. Start the machine and allow it to reach full speed. Make a test cut by nicking the stock. Make any necessary minor adjustment of the stock; then holding the stock firmly against the miter gauge with both hands, feed steadily through the saw.
5. Remove the work before returning the guide to the starting position.

Cutting to length with stop block fastened to rip fence:

1. When many pieces of the same length are to be cut, a stop may be used for measuring. Location of the stop is determined by the length and width of work to be cut.
2. For short pieces, fasten a stop block to the rip fence near the front edge of the table with a clamp. The length of the piece to be cut is measured from this block to a tooth on the saw set toward the fence.
3. Secure the rip fence to the table at the correct cutting position
4. With the work to be cut held against the miter gauge, slide the work along the table until the square end strikes the block. Hold the stock firmly in place and feed into saw, thus cutting to length. Repeat this process for all pieces.

Cutting to length with stop block fastened to miter gauge:

1. Fasten a straight, flat piece of stock to the face of the miter gauge so that it just clears the saw on one end and extends slightly longer than the pieces to be cut on the other end
2. The length of the stock to be cut is measured from a tooth set to the left of the saw. The length is marked on the face of the wood fence piece. A stop block with a square edge is fastened at this point with nails, screws, or a lightweight clamp whichever is suitable.
3. The rip fence must be removed from the table.
4. One end of the work is squared; then this end is held against the stop block while the piece is cut to length.
5. Some miter gauge guides are equipped with a rod for measuring lengths, but when a wood fence piece is used for extending the working face of the guide, the rod is not convenient to use.

Cutting a miter or angle between 30 and 90 degrees:

1. The miter gauge may be set to cut angles between 30 and 90 degrees. The work to be cut is held against the miter gauge which is set at the required angle and the cut is made as in crosscutting.
2. A stop block fastened to the miter gauge may be used in cutting pieces to length as described above.
3. It is very important that the work be held securely against the miter gauge to insure a straight cut.
4. A smooth cut will be obtained if the angle points to the front so that the cut is made with the grain. The long edge of the work will also be against the gauge.
5. When cutting miter on wide stock, tilt the saw or table to the desired angle and proceed as in square crosscutting.
6. When cutting compound angles, set the miter gauge to the desired angle of the face of the stock and set the blade or table to the desired angle of the thickness of the stock. Feed the stock into the saw as described above.

Ripping or cutting to width:

1. A rip or combination saw is adjusted to 1/8" above the thickness of the stock to be cut
2. Use the saw guard and splitter.
3. One edge of the stock to be cut must be straight. This edge is held against the rip fence. A board with an uneven edge should not be cut.
4. Set the rip fence to the required distance to the right of the saw. This may be gauged by the scale on the saw table and check with a rule by measuring between a tooth set to the right and the rip fence.
5. Stand to one side of the saw. Start the saw running and with the straight edge of the board held against the fence, push the board with an even, firm motion to make the required cut.
6. If the cut is made close to the rip fence, use a "push stick" to move the board. Do not reach over the blade to remove the pieces. The section of board between the fence and the saw should always be pushed clear of the saw.
7. Long boards should be supported by a stand the same height as the saw table
8. A device used to keep the board firmly against the fence is called a "feather strip." The spring action of the fingers pushes the board against the fence but allows it to be moved in the cutting direction.

Re-sawing on the circular saw:

1. Set the saw blade 1/8" to 1/4" higher than half the width of the stock to be cut. The saw should not be set to cut deeper than two inches for each cut. Boards wider than four inches should be cut in four steps.
2. Adjust the feather strip to hold the stock firmly against the rip fence.
3. Start the saw and make a cut along one edge.
4. Turn the stock end for end and make the second cut. Make sure the face side is always against the fence.
5. If the stock is more than twice as wide as the saw will cut, the remaining portion may be cut with a band saw or hand rip saw.

Cutting a taper:

1. An adjustable jig may be made as a handy attachment for cutting tapers on the circular saw.
2. The straight edge is held against the rip fence and the piece to be cut is held against the notch of the jig. The jig and the board are pushed past the saw as a unit, making the cut at the desired angle or taper.

Cutting a bevel or chamfer:

1. On most saws either the table or the saw may be tilted so that an angle cut between 45 and 90 degrees may be made.
2. The tilting arbor saw is the most convenient to use. The work may be cut with the fence on either side of the saw. With the tilting table it is easier to make the cut with the fence on the low side of the saw.
3. If the angle to be cut is less than 45 degrees the saw should be adjusted to the supplement of the angle. The trial cut should be checked for the desired angle.

Cutting grooves, rabbets, or dados:

1. Grooves or rabbets may be cut by making a series of closely spaced cuts, but a dado head attachment will do the job much faster. A dado consists of two saws similar to combination saws. These saws may be set to cut grooves from 1/8" to 1" on most popular saws. The throat plate must be replaced either with one supplied with the machine or one made from hard wood.
2. The grooves are cut as in crosscutting or ripping. The guards and splitter cannot be used.
3. A rabbet may also be made by cuts made at right angles- on the adjacent edge and face of the stock.

Cutting stop grooves:

1. Cuts which do not run to the end of the board may be started by lowering the work over the saw.
2. This calls for two stop blocks on a board fastened to the rip fence to limit the travel or cutting length.
3. Hold the board in contact with the fence with one end down on the table and against the stop block nearest the operator. Slowly lower the board the length of the cut until it clears the saw, being careful to maintain contact with the rip fence until the board is clear of the blade.

Tile Saw



There's no substitute for a diamond saw when you have to make fine cuts—corners, curves, slivers—or cut stone or other hard material. The most distinguishing feature of a wet saw is a steady stream of water keeping the saw blade and the tile surface wet during operation. The water helps the blade grind through the tile without breaking it, keeps the blade cool to prevent overheating and significantly reduces the amount of dust that would otherwise be produced when cutting.

Safety

1. Always wear appropriate eye protection.
2. Read and follow MSDS
3. Saw splashes. Wear water proof apron.
4. Always use a push stick when the fence is set under 4" to the blade.
5. Never stand in line with the blade. Stay as far away as possible from the blade.
6. Always unplug the saw when changing the blades. Failure to do this this alone causes many injuries every year around the world.
7. Never reach under blade guard.

How to use

1. Check tile saw to make sure water is in blade tray.
2. Verify the saw is plugged in
3. Take your time. Sawing through tile slowly can help give you cleaner cuts and reduce breakage.
4. Mark the work piece with a lead or grease pencil.
5. Set the work piece against the fence on the sliding saw bed and line up the diamond blade with the cutting mark.
6. Turn on the saw and wait for water to flow over the blade.
7. Hold the work piece on both sides of the cutting line and slowly feed it into the blade.
8. As the cut nears completion, use push bar. Gently push the two halves of the piece together to prevent the tile from breaking before the cut is complete.
9. When the cut is complete, carefully slide the bed and cut tile back toward you until the tile is clear of the blade.
10. Empty blade tray of dirty water. Do not pour water down sink, but please in hazardous waste container

Chop saws and Mitre Saws



Chop Saw



Mitre Saw

Chop saws and mitre saws differ in the way the table allows for the piece to be positioned for angular cuts. The miter saw or chop saw is one of the woodshops most useful tools. It is quick, can be portable and is very accurate. Its speed comes from its ability to be quickly set up and used. Though our saw is fasten securely to the bench, in general when we find a miter saw in use in a personal shop it can be transported and placed where it will be most convenient. These saws are designed to be very accurate when cutting angles and fitted with the proper blade will perform outstandingly.

Chop/Mitre Saw Safety

1. For operation of the chop saw, a full face shield and safety glasses are required. Operators should always wear safety glasses under a full face shield.
2. Gloves, loose clothing, jewelry, or any dangling objects including long hair should not be worn as they may catch in the rotating parts of the saw.
3. All guards must be in place and operating. If a guard seems slow to return to its normal position or hangs up, adjust it or repair it immediately. Unplug or lockout power when making repairs.
4. Place saw on sturdy table for proper support. Make sure saw is stable before starting any work.
5. Hands and fingers must be kept clear of the path in which the blade travels.
6. Clean the lower guard frequently to help visibility and movement. Unplug before adjusting or cleaning.
7. Use only the recommended RPM and sizes of blades. Allow the motor to reach full speed before starting to cut.
8. Regularly check and tighten the blade and the blade-attachment mechanism.
9. Prior to installing or changing a blade, be sure to lockout or unplug equipment. Ensure that the blade and its related washers and fasteners are correctly positioned and secured on the saw's arbor.
10. To avoid losing control or placing hands in the blade path, hold or clamp all material securely against the fence when cutting. Do not perform operations freehand.
11. Never re-cut small pieces. Long material should be supported at the same height as the saw table.
12. Never place hands or fingers in the path of the blade or reach in back of the fence.
13. To avoid contact with a coasting blade, do not reach into the cutting area until the blade comes to a full stop.
14. Don't use the tool in the presence of flammable liquids or gases.
15. Check the blade carefully for cracks or damage before operation. Replace cracked or damaged blade immediately.
16. For your safety, remove chips, small pieces, etc. from the tabletop before operation.
17. Avoid cutting nails. Inspect for and remove all nails from the workpiece before operation.
18. Make sure the shaft lock is released before the switch is turned on.
19. Never reach around saw blade.
20. Stop operation immediately if you notice anything abnormal.
21. Do not attempt to lock trigger in the on position.
22. Don't abuse cord. Never yank cord to disconnect it from the receptacle. Keep cord away from heat, oil, water and sharp edges.
23. Inform the shop supervision if the tool seems to be malfunctioning or is damaged.

24. After completing a cut, release the trigger switch and allow the blade to come to a complete stop, then raise the blade from the work piece. If the blade stays in the cutting area after the cutting is complete, injury can result from accidental contact.

The Tool and its Parts

Handle Latch

This tool is equipped with a handle latch, which is used to lock the handle in the lower position. To release from the lowered position, lower the handle slightly and turn the handle latch to the released position. To lock the handle in the lowered position, lower the handle fully and turn the handle latch to the locked position. When carrying the tool, lock the handle in the lowered position and secure the turn base by means of the grip.

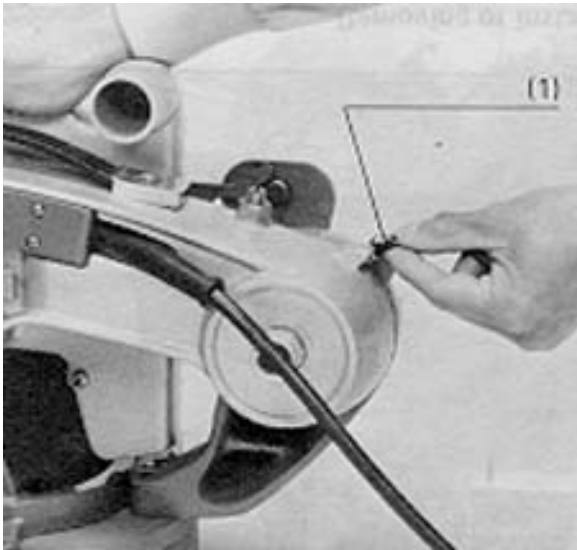

(1) Handle Latch

Fig. 1

Removing or Installing Saw Blade

CAUTION: Always be sure that the tool is switched off and unplugged before removing or installing the blade.

To remove the blade, use the socket wrench to loosen the hex bolt holding the center cover by turning it more than three turns counter clockwise. Raise the safety cover and center cover.

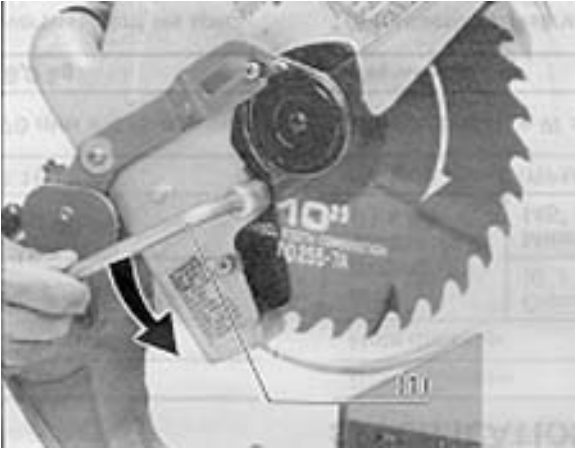

(1) Socket Wrench

Fig. 2

Press the shaft lock so that the blade cannot revolve and use the socket wrench to loosen the hex bolt clockwise. Then remove the hex bolt, outer flange and blade.



(1) Shaft Lock

Fig. 3

To install the blade, mount the blade onto the spindle, making sure that the direction of the arrow on the surface of the blade is compatible with that on the blade case. Install the outer flange and hex bolt, and then use the socket wrench to tighten the hex bolt securely counter clockwise while pressing the shaft lock.



Fig. 4

Slip the pin on the safety cover into the slot in the guide arm while returning the safety cover to its original fully closed position. Then tighten the hex bolt clockwise to secure the center cover.



Fig. 5

Safety Cover

When lowering the handle, the safety cover rises by means of the guide arm. The cover returns to its original position when the cut is completed and the handle is raised. **NEVER DEFEAT OR REMOVE THE SAFETY COVER.** In the interest of your personal safety, always maintain the safety cover in good working condition. Any irregular operation of the safety cover should be corrected immediately. **NEVER USE THE TOOL WITH A FAULTY SAFETY COVER.** If the see through safety cover becomes dirty, or sawdust adheres to it in such a way that the blade and/or workpiece is no longer easily visible, unplug the saw and clean the cover carefully with a damp cloth. Do not use solvents or petroleum-based cleaners on the plastic cover.



(1) Safety Cover

Fig. 6

Switch Action

To prevent the trigger from being accidentally pulled, a lock-off button is provided as a safety feature. To start the tool, press in the lock-off button and pull the trigger. Release the trigger to stop.

CAUTION:

- Before plugging in the tool, always check to see that the trigger switch actuates properly and returns to the "OFF" position when released.
- When not using the tool, remove the lock-off button. This prevents unauthorized operation.



(1) Lock -off Button

(2) Trigger Switch

Fig. 8

Kerf Board

This tool is provided with the kerf board in the turn base. This allows the blade to cut cleanly through your workpiece, preventing tear out.

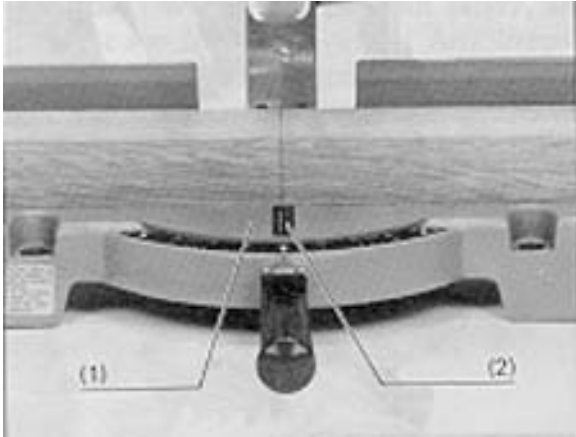

Fig. 9

- (1) Turn Base
- (2) Kerf Board

Positioning for Miter Angle

Loosen the grip by turning counter clockwise. Press down the latch spring. This allows the turn base to turn freely. When you have moved the grip to the position where the pointer indicates the desired angle on the miter scale, release the latch spring and securely tighten the grip clockwise.

NOTE:

The latch spring automatically locates miter angles of 0, 15, 22.5, 30 and 45 degrees. To select one of these angles, turn the turn base near the desired angle while releasing the latch spring and allow the latch spring to seat itself in the miter notch. Then tighten the grip securely.

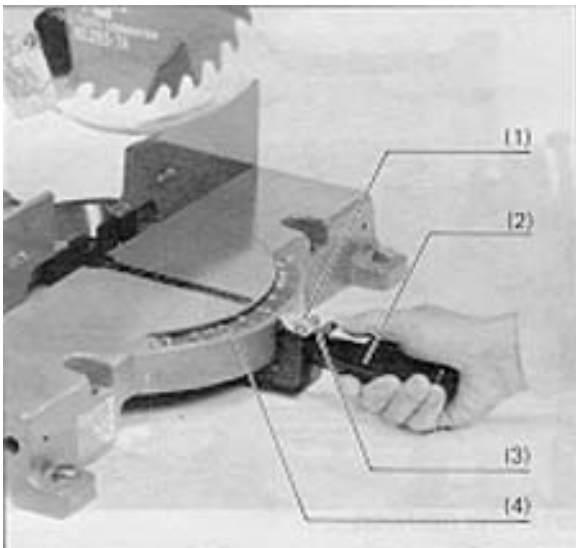
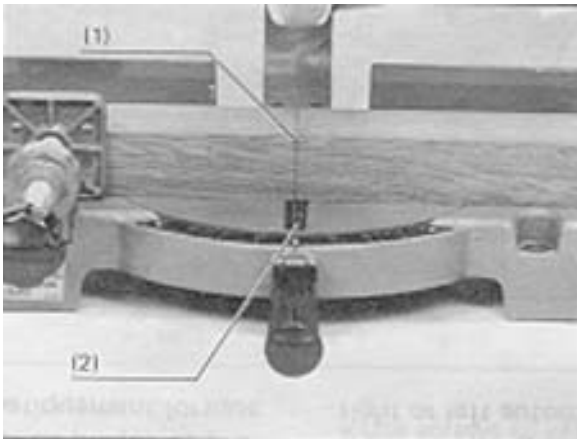

Fig. 10

- (1) Pointer
- (2) Grip
- (3) Latch Spring
- (4) Miter Scale

Operation

When cutting with this tool, the thickness of the blade is cut as well. Therefore, your cutting line should be on either the left or right side of the groove in the kerf board. Switch on the tool and wait until the blade attains full speed before lowering gently into the cut. When the blade contacts the workpiece, gradually bear down on the handle to perform the cut. When the cut is completed, switch off the tool and **WAIT UNTIL THE BLADE HAS COME TO A COMPLETE STOP** before returning the blade to its fully elevated position. A thin piece could otherwise contact the coasting blade and be thrown out dangerously.



(1) Cutting Groove
(2) Groove

Fig. 11

Securing Workpiece

Hold the workpiece firmly against the guide fence. Exercise extreme caution and keep your hands away from the blade area during operation.

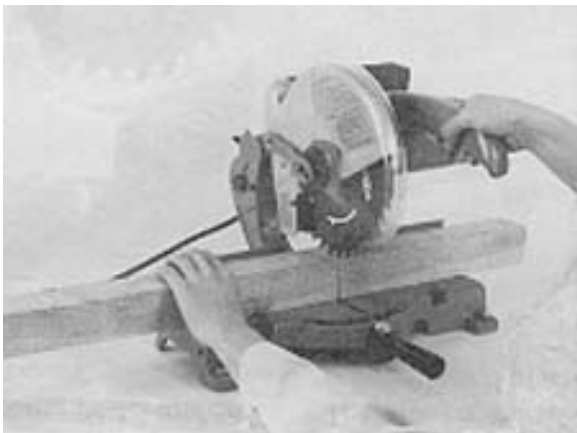

Fig. 12

Fence Plate

The fence plate is designed to prevent smaller cutting scraps from jamming inside the blade case. The fence plate moves right or left automatically as the turn base is rotated.

Wood Facing

Use of wood facing helps to insure splinter free cuts in workpieces. Attach a wood facing to the guide fence using the holes in the guide fence.



Fig. 13

CAUTION:

- Use straight wood of even thickness as the facing.
- See the figure below concerning the dimensions of a suggested wood facing.

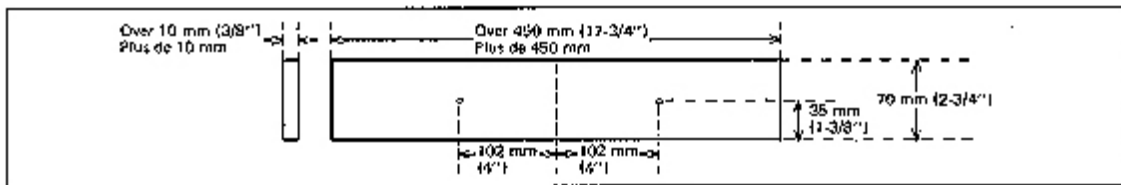
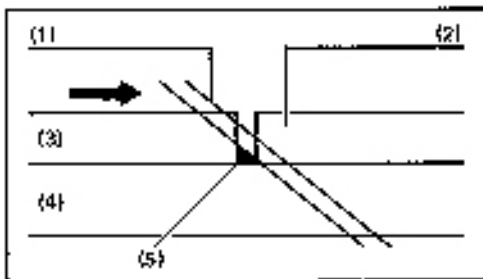

Fig. 14

- Use screws to attach the wood facing to the guide fence. The screws should be installed so that the screw heads are below the surface of the wood facing.
- After changing the miter angle, cut the wood facing at the selected angle. If there is a gap between the blade, the wood facing and the workpiece, move the wood facing slightly in the direction of the arrow and cut again.



(1) Blade

(2) Wood Facing

Fig. 15

(3) Wood Facing (4) Workpiece
 (5) There should be no gap between the blade, the wood facing and the workpiece.

- When the wood facing is attached, do not turn the turn base with the handle lowered. The wood facing will be damaged.

NOTE:

When the wood facing is attached the maximum cutting capacities in width, will be reduced by the thickness of the wood facing.

Adjusting the Smooth Handle Action

The hex lock nut holding together the gear housing and arm has been factory adjusted to assure smooth handle action up and down and to guarantee precise cutting. **DO NOT TAMPER WITH IT.** Should looseness develop at the gear housing and arm connection, inform the technician and he will perform the following adjustment. Work the handle up and down while tightening the hex lock nut; the best position to tighten the hex lock nut is just before the motor body weight is obvious.



Fig. 16

(1) Gear Housing
 (2) Hex Lock Nut
 (3) Arm

After adjusting the hex nut, be sure the handle returns automatically to the initial position from any position. If the hex lock nut is too loose, the cutting accuracy will be affected; if it is too tight, it will be hard to work the handle up and down. Note that this is a self- locking nut; it is a special type that does not work loose under normal use. It should not be over tightened or replaced with other types of nuts.

Alignment for Squareness

This tool was carefully adjusted and aligned for squareness of cut at the factory, but rough handling may have affected the alignment. If your tool is not aligned properly ask the technician to perform the following.

Loosen the grip and set the turn base at zero degree by turning the turn base and allowing the latch spring to seat itself in the miter notch. If the pointer on the indication plate is not at zero on the miter scale, gently tighten the grip and loosen the screws on the indication plate. Adjust the indication plate

so that the pointer will be at zero on the miter scale. Then tighten the screws on the indication plate. Tighten the grip securely and loosen the hex bolts on the guide fence. Square the guide fence using a triangular rule; try-square, etc. Then securely tighten the hex bolts on the guide fence.

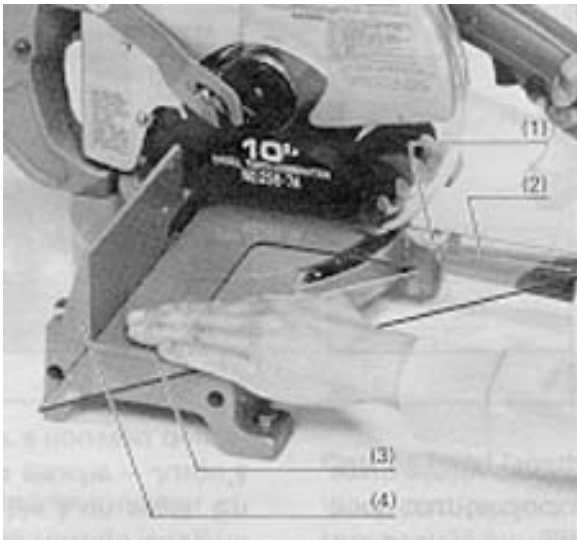

Fig. 17

- (1) Pointer (Indication Plate)
- (2) Grip
- (3) Triangular rule
- (4) Guide Fence

Cutting Fixed Lengths

When cutting several pieces of stock to the same length it is best to use a stop to insure accuracy in your cutting. This can be accomplished simply, by setting your first cut accurately and then clamping a piece of scrap to the worktable abutting your workpiece. By placing your remaining pieces gently against your new stop you can be assured that they will all be the same length.

*This manual as been extracted in part from the owners manual for the: **Makita 10" Miter Saw, Model LS1020***

WELDING



Welding equipment includes MIG, TIG, and STICK, Gas Welding as well as Oxy-acetylene and plasma cutting. The principles can be taught to students but hands-on practice develops welding skills.

Welding Safety Guidelines

- 1. Shop staff approval is required before using any welding equipment.**
2. Welders, assistants, and anyone else in the welding area shall wear glasses or shields of recommended shades during welding operations.
3. The welder is responsible for erecting a screen around the welding area to protect other personnel in the shop from eye injury.
4. Inspect all welding equipment to be used, prior to each use, for possible damage.
5. Avoid handling oxygen bottles with greasy hands, gloves or rags. Fatal explosions have resulted from this cause.
6. Always strap tanks to a welding cart or a fixed object. Never allow a gas cylinder to be free standing. Replace the safety cap on all cylinders when not in use.
7. When arc welding, make sure work and/or work table is properly grounded.
8. Do not arc weld in a wet area.
9. Be alert to possible fire hazards. Move the object to be welded to a safe location, or, **remove all flammable materials from the work area.**
10. Never weld in the same area where degreasing or other cleaning operations are performed.
11. Keep suitable fire extinguishing equipment nearby and know how to operate it.
12. Shut off the cylinder valves when the job is completed, release pressure from the regulators by opening the torch valves momentarily and back out regulator adjusting valves. Never leave the torch unattended with pressure in the hoses.
13. Utilize all protective equipment and clothing. Do not arc weld with any part of the body uncovered, the arc light is actinic light (excessive ultraviolet) and will cause burns similar to severe sunburn.
14. Never weld inside drums or enclosed spaces without adequate ventilation, or, the use of

airline respirators or self-contained breathing apparatus.

15. Check the ventilation system before starting to weld and periodically thereafter to insure adequate performance. **Welding fumes should not be allowed to get into the rest of the shop working areas.**
16. Never cut or weld any container that has held explosive or flammable materials. Use prescribed methods for cleaning or flooding.
17. Never use wrenches or tools except those provided or approved by the gas cylinder manufacturer to open valves. Never use a hammer to open or close valves.
18. Abide by any other safety measures required for each particular type of welding.
19. Allow for proper ventilation when brazing or soldering. The fluxes are acidic and toxic.
20. Do not weld on painted, galvanized or greasy, oily metals. Not only can the fumes be toxic, but the welds will not be satisfactory and will fail in use.

MEASURING

Measuring Rule

Dial Caliper

Micrometer

Measuring Rules

Industry regularly makes measurements to a millionth (0.000001) part of an inch. A distance this small is called a MICROINCH. If the micro inch were the thickness of a dime and inch would be as high as four Empire State Buildings. In addition to the English measurement (inch, foot, etc.), industry, to a limited extent, also uses the metric system of measurement (meter). The United States has tentatively adopted the simplified and clarified metric system devised by the International Standards Organization (ISO). All of the states are in the process of converting to the metric system of the next several years.

Regardless of how fine industry can measure, the job at hand is to learn to read the rule to 1/64 in.; progress through 1/1000 (0.001) in. by micrometer and Vernier type measuring tools; and finally to 1/10000 (0.0001) in. by the Vernier scale on the hub of some micrometer calipers.

Metric based measuring tools will offer no problems. As a matter of fact, many think they are easier to learn to read than inch based measuring tools.

The Rule

Types of Rules

The steel rule, often a scale, is the simplest found in the shop. See basic types of rule the many rule styles are 2g.

Reading the Rule

A careful study of rule, Fig 4-3, will show divisions of the inch lines representing the GRADUATIONS. On graduation is numbered every eighth graduation on the

The best way to learn to read the rule is to:

1. Become thoroughly familiar with the 1/8 and 1/16 measurements.
2. Do the same with the 1/32 and 1/64 measurements
3. Practice until you become proficient enough to read measurements accurately and quickly.

Some steel rules (inch based) are graduated in 10^{ths}, 20^{ths}, 50^{ths} and 100^{ths}. Additional practice will be necessary to read these rules accurately and quickly.

Fractional measurements are always reduced to the lowest terms. A measurement of 14/16 is 7/8, 2/8 is 1/4 etc.

Care of the Rule: The steel rule is precision made and, like all tools the quality of service depends upon the care it receives.

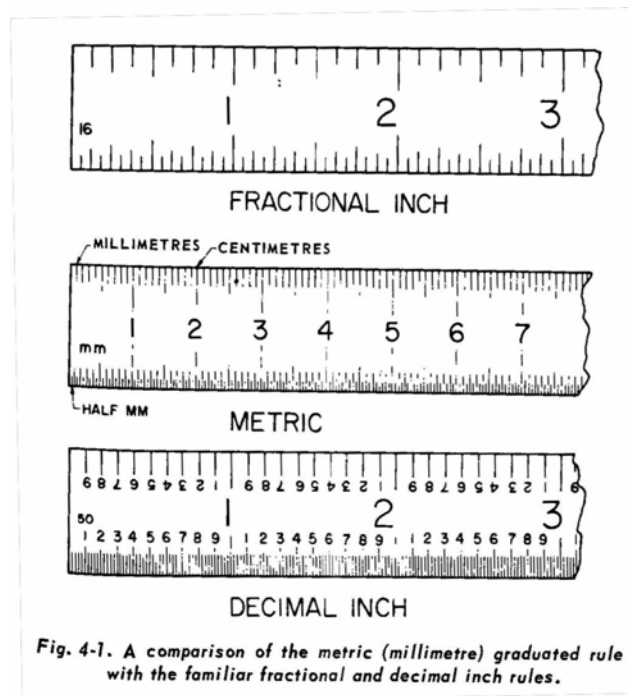

incorrectly referred to as of the measuring tools Fig. 4-1 for the three graduations. A few of shown in Fig. 4-2a to

the enlarged section of the the different fractional from 1/8 to 1/64 in. The divisions are called many rules, every fourth on the 1/32 edge, and every 1/64 edge.

Dial Calipers

A popular and quick instrument to use, the dial caliper measures inside, outside and depth dimensions.

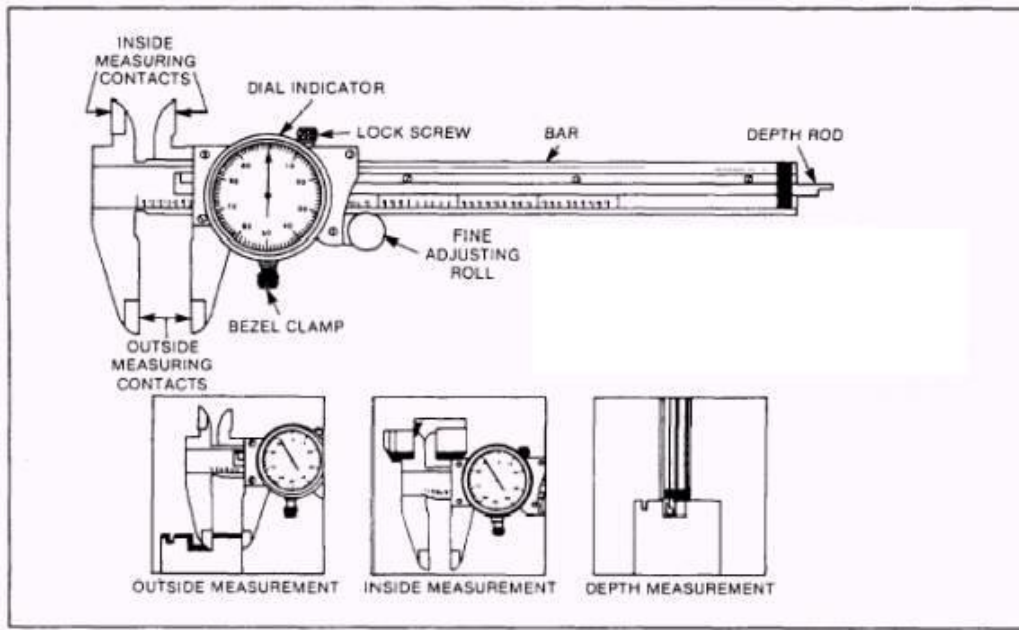

Calipers with a dial are much easier to read than the old dial-less slide vernier calipers. They eliminate eye strain. Always double check a caliper reading! Set the dial to zero in the closed position before measuring.

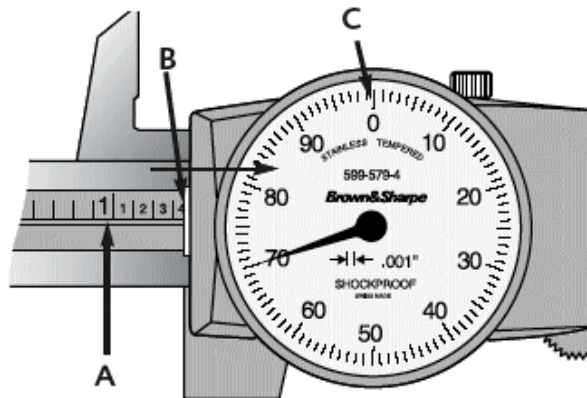

It might seem intimidating and complicated, in reality dial calipers are simple to read once you get the hang of it. You read it in the order A, B, C as the diagram above shows. If the hand on the dial is between two numbers you just need to estimate the reading. If you see the hand is exactly in the middle round up. That would make the reading showing on this dial caliper 1370 thousandths.

USING CALIPERS

CALIPERS

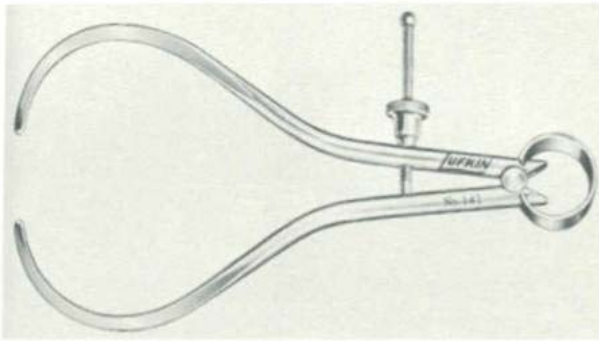

Fig. 5-1. The spring-joint outside caliper.

The OUTSIDE CALIPER, Fig. 5-1, is used to make external measurements where a 1/64 in. tolerance is permitted. A caliper does not have a dial or gauge which shows a measurement, and must be used with a steel rule.

Round stock is measured by setting the caliper to the approximate diameter of the material.

Adjust the tool until the caliper points bear lightly on the centerline of the stock. The weight of the caliper should cause the tool to pass over the diameter. Hold the caliper to the rule, Fig. 5-2, to read the size.

The INSIDE CALIPER, Fig. 5-3, is used for making internal measurements where 1/64 in. accuracy is acceptable.

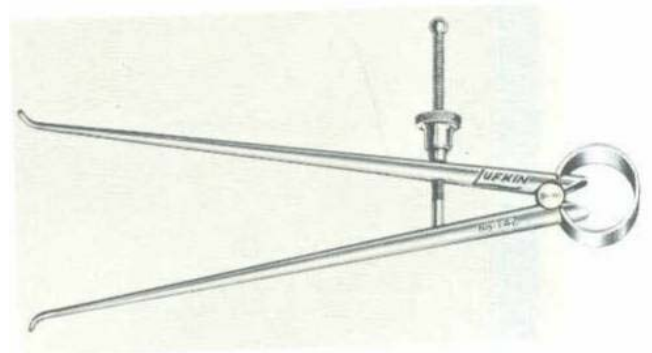

Fig. 5-3. The spring-joint inside caliper.

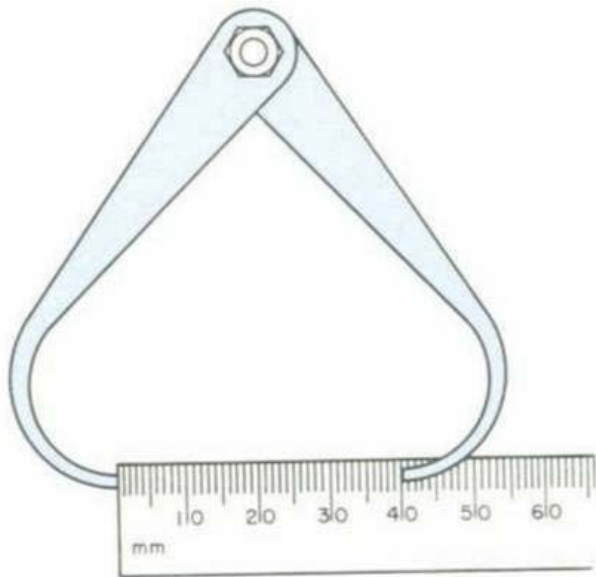

Fig. 5-2. Setting outside calipers.

A hole diameter can be measured, Fig. 5-4, by setting the caliper to the approximate size of the hole, and inserting the legs into the opening. Hold one leg firmly against the hole wall, and adjust the thumbscrew until the other leg lightly touches the wall exactly opposite the first leg. The legs should “drag” slightly when moved in and out, or from side to side. Read the hole size by holding the caliper to a steel rule, Fig. 5-5.

There are times when a shaft must be turned to fit a hole, and it becomes necessary to transfer the measurement from one caliper to another. This can be accomplished quickly by setting the inside caliper to fit the hole diameter. Place one leg of the inside caliper against one leg of the outside

Then, hold the caliper square with the work and move the caliper legs down on the stock.

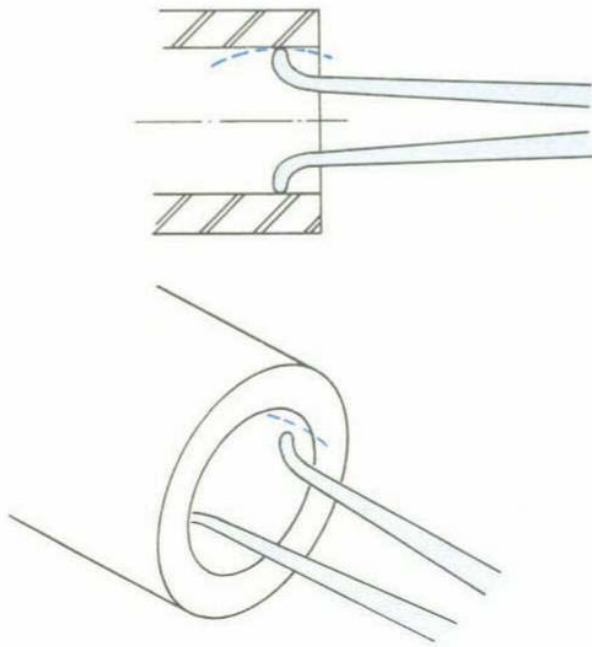

Fig. 5-4. Measuring with the inside caliper.

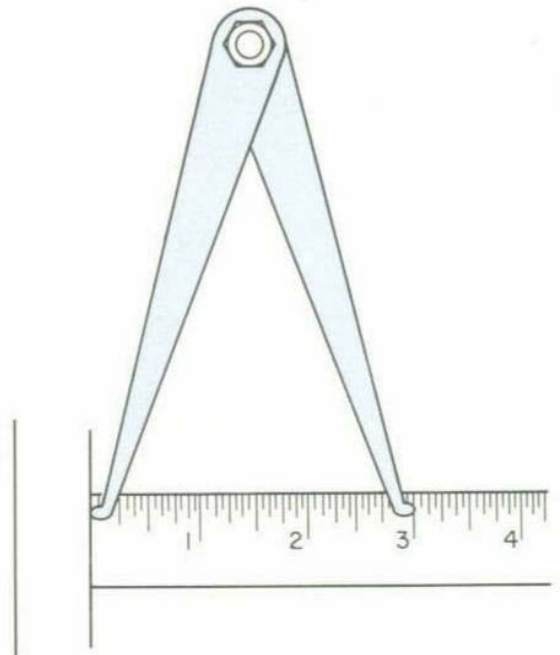

Fig. 5-5. Reading the inside caliper.

caliper, and adjust the outside caliper until the second leg lightly touches the other leg of the inside caliper.

Considerable skill is required to make accurate measurements with calipers. Much depends upon the machinist's sense of touch. With practice, measurements to within 0.003 to 0.005 in. can be made. A micrometer or Vernier caliper should be used if greater accuracy is required.

TEST YOUR KNOWLEDGE

1. The _____ caliper is used to make external measurements.
2. The _____ caliper is used to make internal measurements.
3. Calipers are used where _____ in. accuracy is acceptable.
4. A _____ or _____ caliper should be used when accuracy closer than 0.003 to 0.005 is required.

Using a Micrometer



Pictured above is an "outside micrometer". This is a tool often used in manufacturing environments to make precision measurements of the outside dimensions of a piece. Let's take a look at some of the parts of this instrument:



Note that the distance measured is the distance between the spindle and the anvil. The piece is inserted here, and the spindle length is adjusted so that the piece being measured just touches the anvil and the spindle.

The thimble is rotated to increase or decrease the distance between the spindle and anvil, and the measurement is read from numbers printed on the barrel and the bevel of the thimble.

Now that we know what the different parts are, and how they are used, all we need to know is how to read the measurements. Although micrometers come in different sizes, they are all read in the same way. The example we will look at measures from 0 to 1 inch, with an accuracy of 1/1000 of an inch.

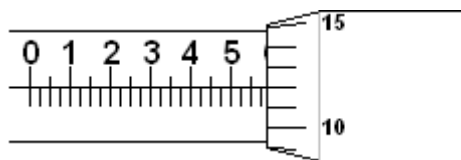

Above is a close-up of the barrel and thimble.

How to Read Vernier Micrometer

Most micrometers can read to one thousandth of an inch (0.001").

Vernier micrometers can read to one ten-thousandth of an inch (0.0001").

Consider the micrometer reading shown below:

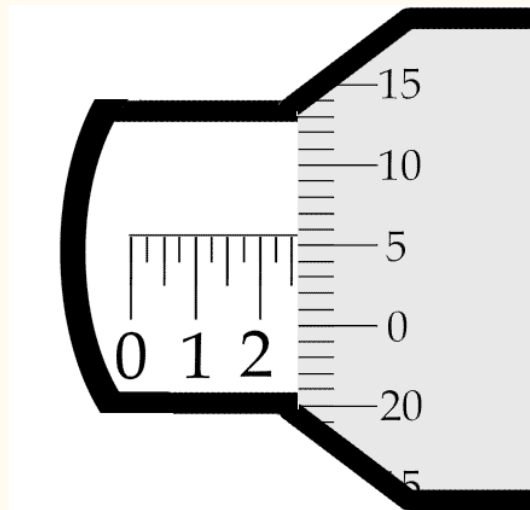

If this was a 0 - 1" micrometer it would read somewhere between 0.255" and 0.256".
(250 on the Sleeve, with more than 5, but less than 6 on the Thimble).

Usually this would be close enough however sometimes we need to be more accurate.

Vernier micrometers have lines marked on the sleeve that let you read ten-thousandths of an inch. Each line is equal to .0001".

To show all the vernier markings I have "flattened" the sleeve of the micrometer. A real micrometer looks a little different and I encourage you to ask for a vernier micrometer so you can experiment with the real tool.

In the figure shown below, I have the same reading as before, only now we are using the vernier micrometer.

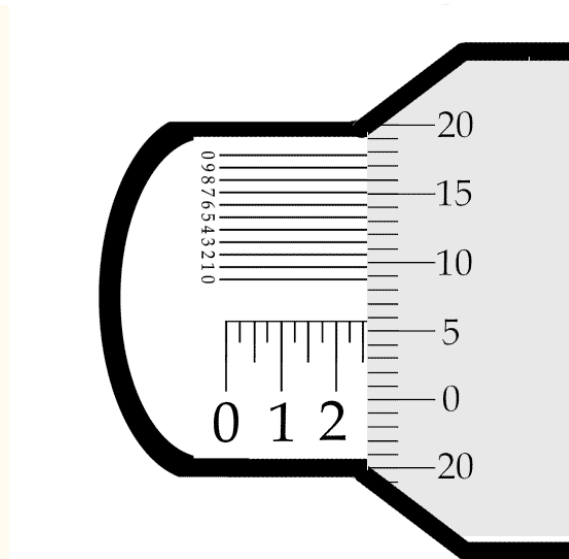

The above micrometer reads 250 on the Sleeve and 5 on the Thimble = 0.255. Now look for the vernier mark that lines up closest to any of the lines on the Thimble. In this case it is the vernier marked 8. The micrometer shown above reads 0.2558

It is easy to read what the micrometer is telling you. It is VERY difficult to accurately measure to .0001". This is due to the delicate feel that you must have to make this accurate of a measurement. Before you believe what your hands and micrometer are telling you, you must make several measurements to ensure you get consistent results.

Practice reading the Vernier Micrometer

You will quickly improve if you practice with a real micrometer.

LAYOUT

LAYOUT WORK

LAYING OUT is the term used to describe the locating and marking out of lines, circles, arcs and points for drilling holes. These lines and reference points on the metal show the machinist where to machine.

The tools used for this work are known as LAYOUT TOOLS. Many common hand tools fall into this category. The accuracy of the job will depend upon the proper and careful used of these tools.

Making Lines on Metal

The shiny finish of metal makes it difficult to distinguish the layout lines from the metal. LAYOUT DYE, Fig. 6-1, is probably the easiest to use of the many coating devised to make the lines stand out better. This blue colored fluid, when applied to the metal, offers an excellent contrast between the metal and the layout lines. All grease and oil must be removed before applying the dye, otherwise it will not adhere properly.

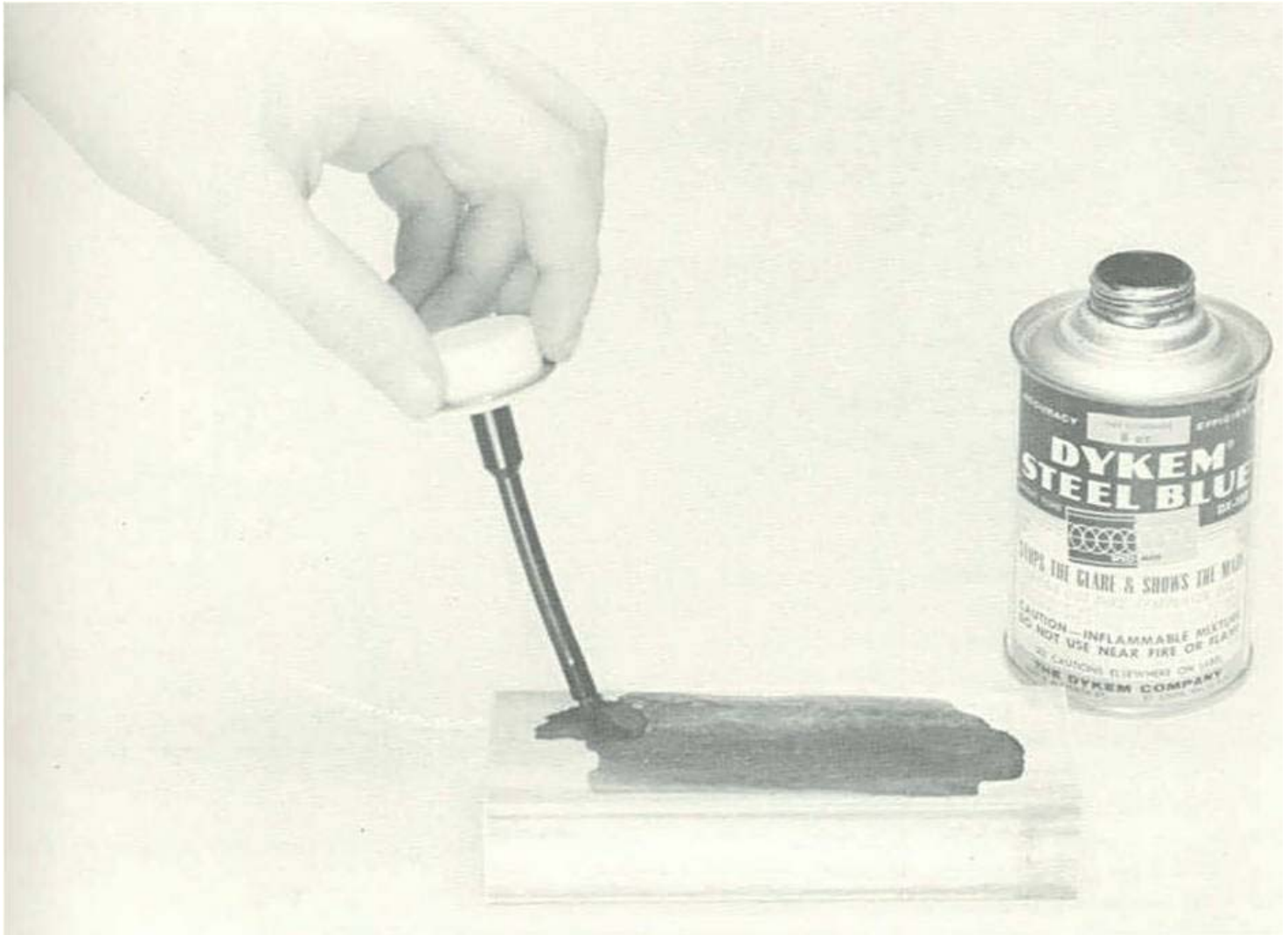

Fig. 6-1. Applying layout fluid preparatory to making the layout.

In a pinch, layout fluid can be made by dissolving the coating on spirit duplicator carbons in alcohol. Chalk can be used on hot rolled metal as a layout background.

A layout, to be accurate, requires fine lines that must be scribed or scratched in the metal. A SCRIBER, Fig. 6-2, is used to produce these lines.

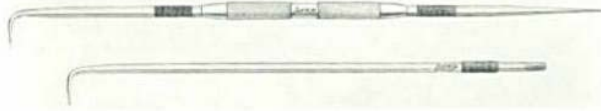

Fig. 6-2a. Scriber.



Fig. 6-2b. Pocket scriber. The point is reversed and stored in the handle when the tool is not being used.

The point is made of hardened steel, and is kept needle sharp by frequent honing on a fine oilstone. Many styles of scribers are available. CAUTION: NEVER CARRY AN OPEN SCRIBER IN YOUR POCKET.

The scriber is used to draw straight and gradually curved lines, circles and arcs are made with the DIVIDER, Fig. 6-3a.

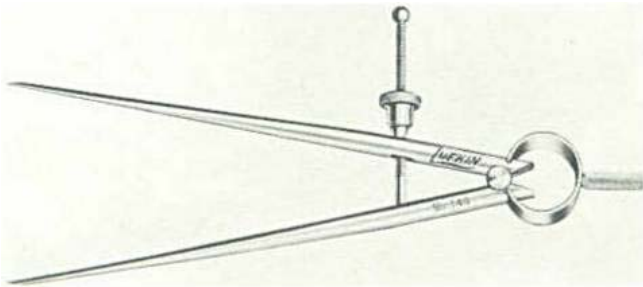

Fig. 6-3a. The divider.

It is essential that both legs of the tool be equal in length and kept pointed. The divider can be used to lay out and measure distances, Fig. 6-3b. To set the tool to the correct dimension, place one point on an

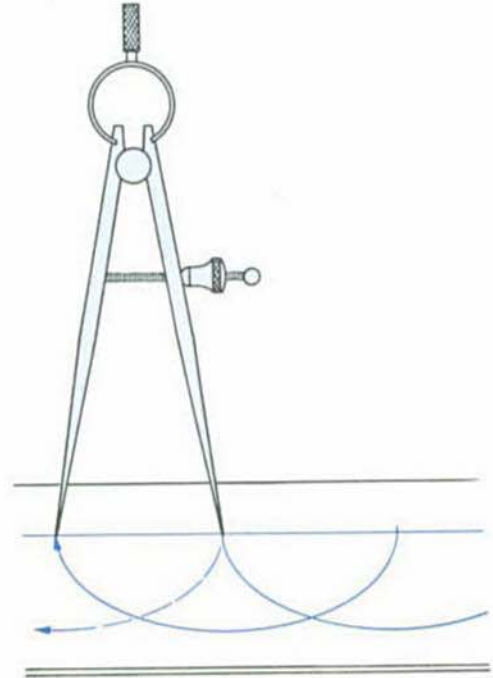

Fig. 6-3b. Laying out equal spaces with a divider.

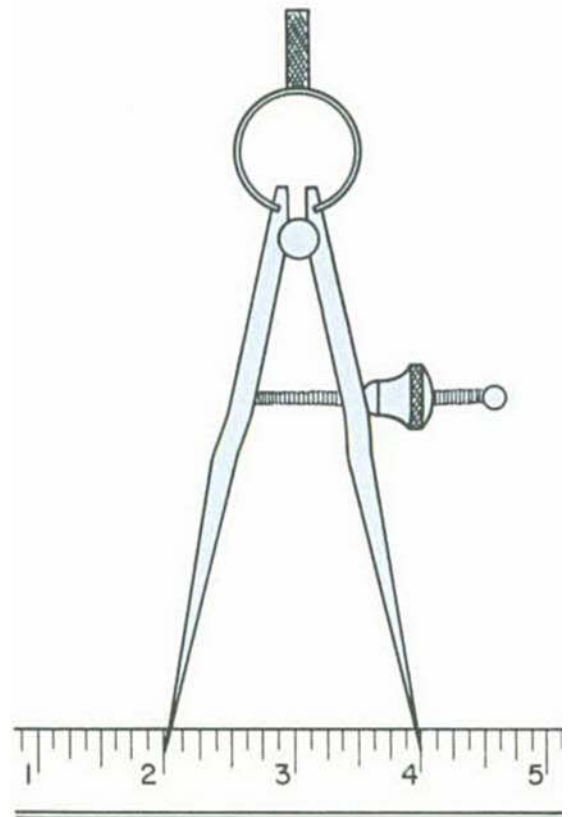

Fig. 6-3c. Setting a divider to the correct dimension.

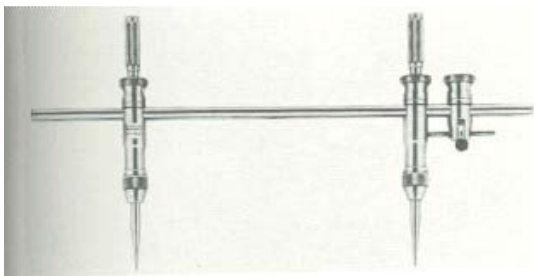

Fig. 6-4. The trammel.

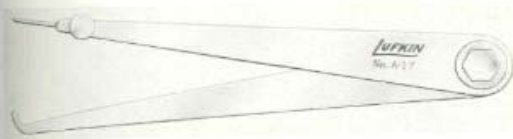

Fig. 6-5a. Hermaphrodite caliper.

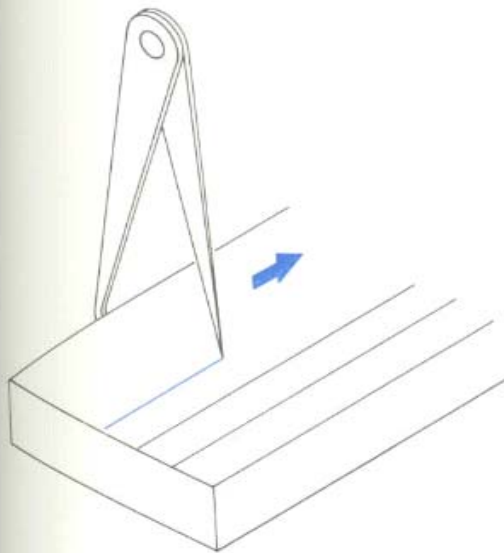

Fig. 6-5b. Laying out lines parallel to edge with hermaphrodite caliper.

inch mark of steel rule, and open the divider until the other leg is set to the proper distance, Fig. 6-3c.

Circles and arcs that are too large to be made with the divider are drawn with a trammel, Fig. 6-4. This consists of a long thin rod, called a BEAM, on which two SLIDING HEADS with scribe points are mounted. One head is fitted with an ADJUSTING SCREW. EXTENSION RODS can be added to the beam to increase the capacity of the tool.

The HERMAPHRODITE CALIPER, Fig. 6-5a, is a layout tool which has one leg shaped like a caliper, and the other pointed like a divider. The tool is used to lay out

lines parallel to the edge of the material, Fig. 6-5b, and to locate the center of irregularly shaped stock.

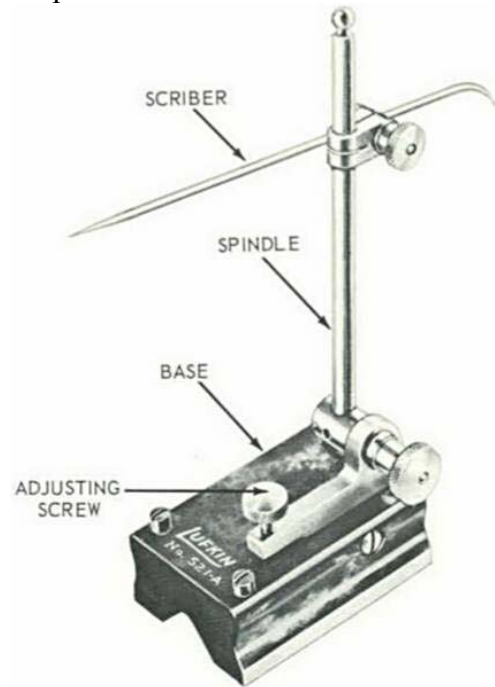

Fig. 6-6a. Surface gauge.

A SURFACE GAUGE, Fig. 6-6a, is used for many purposes, but is most frequently used for layout work. It consists of a BASE, SPINDLE and SCRIBER.

An ADJUSTING SCREW is fitted for making fine adjustments. The scriber is mounted in such a manner that it can be pivoted into any position. The surface gauge can be used for scribing lines, at a given height and parallel to the surface, Fig. 6-6b. A V-slot in the base permits the tool to be used on a curved surface.

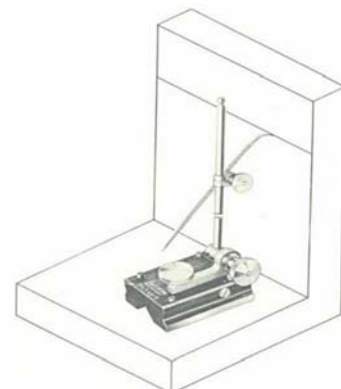
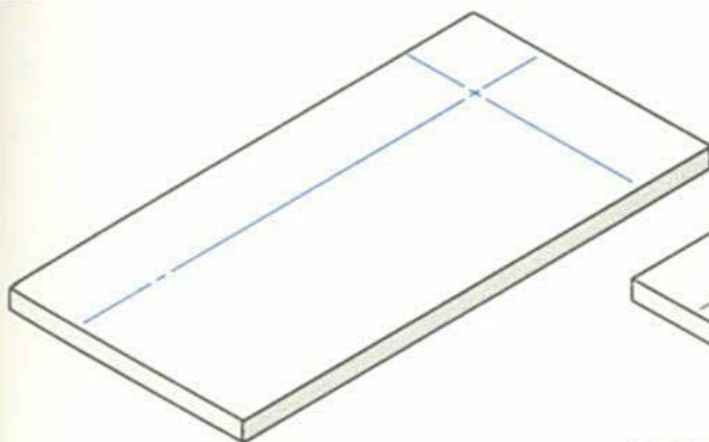
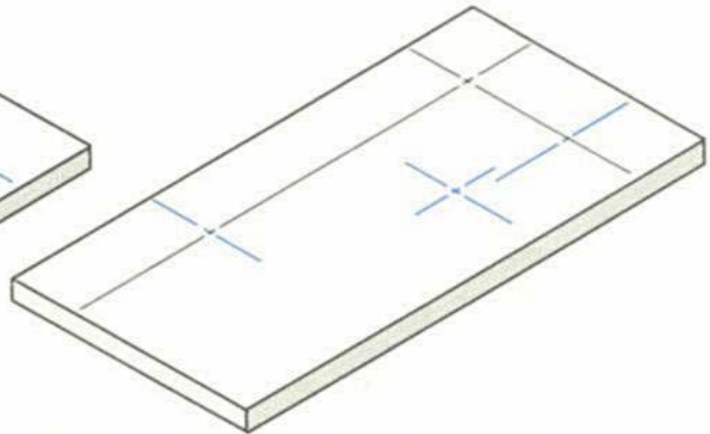

Fig. 6-6b. Using surface gauge to scribe lines parallel to base.



1. LOCATE AND SCRIBE THE BASE LINES



2. LOCATE ALL CIRCLE AND ARC CENTER LINES

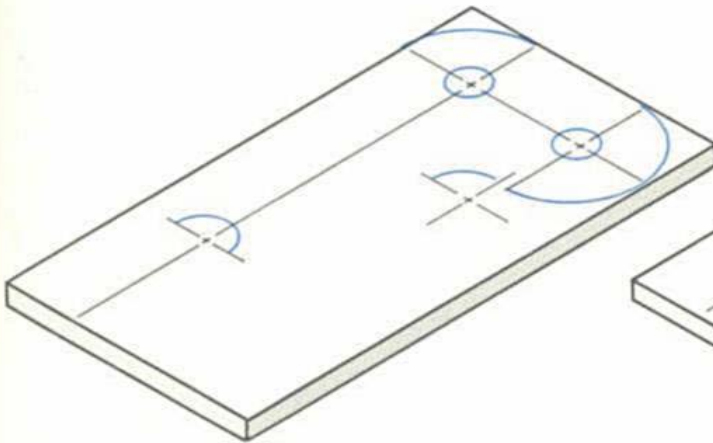

3. SCRIBE IN ALL CIRCLES AND ARCS

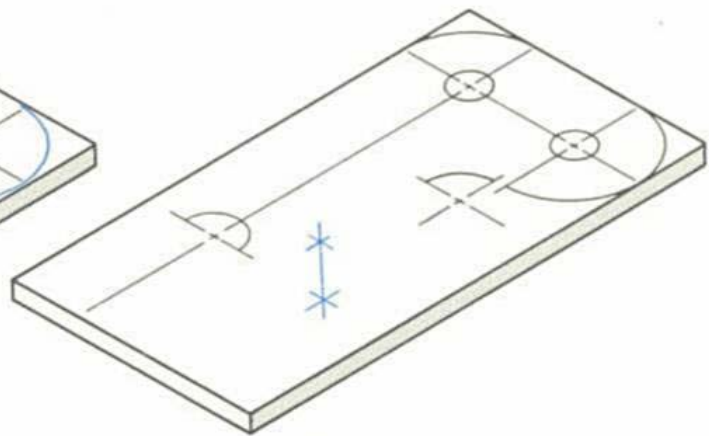

4. LOCATE AND SCRIBE IN ANGULAR LINES

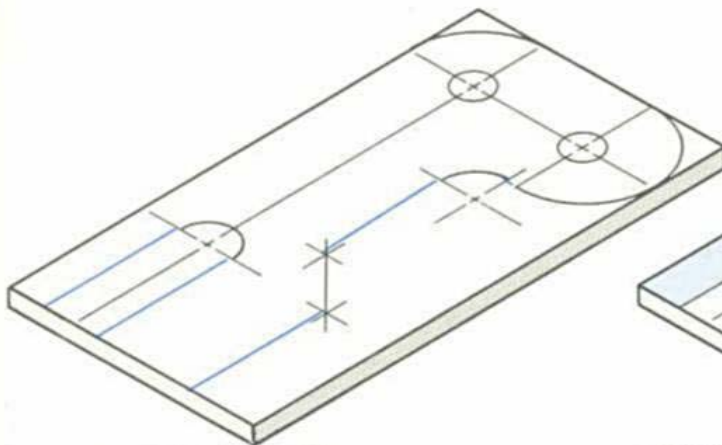

5. SCRIBE IN REMAINING LINES

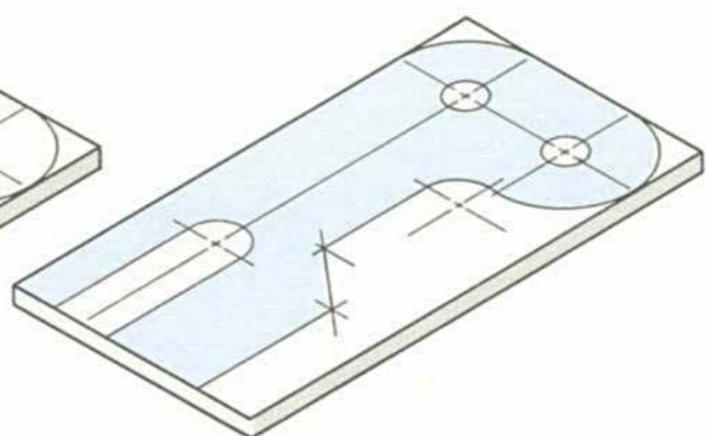

6. FINISHED LAYOUT OF PART

Fig. 6-19. Steps in laying out a job.

Steps in Making a Layout

Each layout job has its peculiarities and requires some planning before the operation can be started. Fig. 6-19 shows a typical job.

1. Study the drawings carefully.
2. Cut the stock to size and remove all burrs and sharp edges.
3. Clean the work surface of all oil and grease and apply layout dye.
4. Locate and scribe a REFERENCE or BASE LINE. Make all of your measurements from this line. If the material has one true edge, it can be used in place of the reference line.
5. Locate the center points of all circles and arcs.
6. Use the PRICK PUNCH, Fig. 6-20, to mark the point where the center lines intersect. The sharp point (30 to 60 deg.) of this punch makes it easy to locate this position. After the prick punch mark has been checked and found on center, it is enlarged with the CENTER PUNCH, Fig. 6-20.
7. Using the divider or trammel, scribe in all circles and arcs.
8. If angular lines are necessary, use the proper protractor type tool, or locate the correct points by measuring, and connect them by using a rule or straightedge.
9. Scribe in all other internal openings.
10. Use only clean sharp lines.

Modern Metalworking

S A F E T Y

1. Never carry an open scribe, divider, trammel or hermaphrodite caliper in your pocket.
2. Always cover all sharp points with a cork when the tool is not being used.
3. Wear goggles when grinding the points of scribe type tools.
4. Get help when you must move heavy angle plates, large V-blocks, etc.
5. Remove all burrs and sharp edges from stock before starting to work on it.

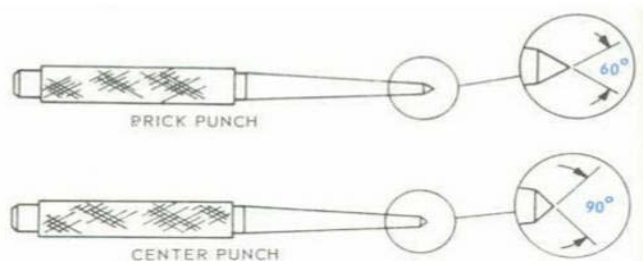
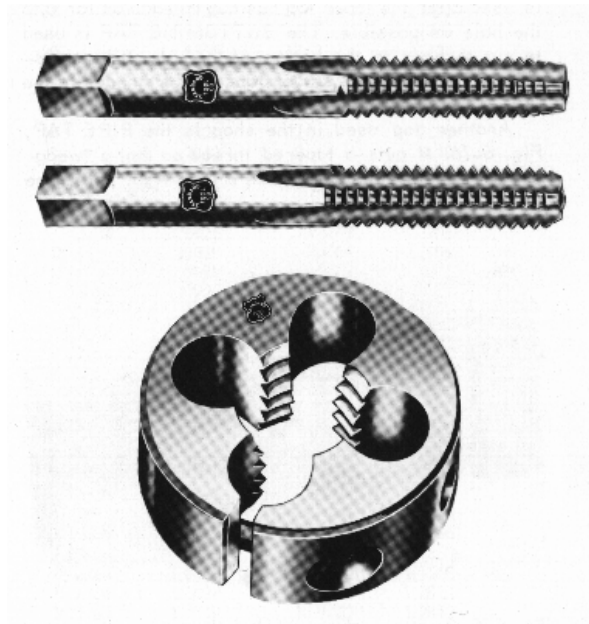

Fig. 6-20. Differences between a prick punch and a center punch.

TAPS AND DIES



*From top to bottom: tapered tap,
bottoming tap
and die.*

HOW TO USE TAPS AND DIES

ABOUT TAPS AND DIES:

American Standard Taps and Dies are designated according to the Metal Cutting Institute Standard System of Marking as follows:

1. Nominal size such as a fraction or number representing the major diameter of the thread.
2. Number of threads per inch
3. Symbol to identify the thread types

Metric Taps and Dies are designated as follows:

1. A number representing the major diameter of the thread
2. The symbol MM indicating metric
3. A number which is the pitch (or distance from the crest of one thread to the crest of the next thread) of the thread in millimeters

TAPS

WHAT A TAP IS – WHAT A TAP DOES

A tap is a precision tool used in the cutting of an internal thread such as in a nut. Just a drill removes material to make a hole, a tap cuts material away to form a thread. There are three basic types of hard taps: i.e., “taper”, “plug”, and “bottom” taps. The difference in these is the length of the chamfer on the starting end of the tap. “Taper” taps are chamfered for the first 6-8 threads. This makes starting easier but prevents threading close to the bottom of a hole. “Plug” taps are chamfered 3-5 threads from the end. This is the optimum for starting and being able to tap close to the bottom of a hole. “Bottoming” taps have a very short chamfer, 1 1/2-3 threads, and will tap as close to the bottom of a hole as practical; however, to do this requires starting the thread with a “plug” or “taper” tap first.

TOOLS REQUIRED TO MAKE A THREADED HOLE

1. A Tap of the correct size and thread form
2. A Tap wrench
3. Proper drill size or hole size
4. Lubrication or cutting oil

The correct drill or hole size is of great importance in producing satisfactory threads. The Tap Drill Chart (see later pages) provides a ready reference table of the correct drill sizes. Use of a smaller drill than specified does not provide a stronger or tighter thread. It only serves to overload the tap and cause undue breakage. Lubrication of the tap while cutting threads is important in producing smooth threads and maintaining long tap life. Refer to the lubrication section for recommendations.

RENEWING THREADS

Damaged, mutilated, or rusty threads are easily repaired. First check the part for correct thread size and select the proper tap. Next carefully start the tap into the pre-threaded hole and proceed in the same manner as when cutting new threads. Some materials are case hardened and if a tap is forced into work in this type, damage to the tap will result. A simple file test will determine whether or not to proceed. If material can not be easily filed, do not attempt to rethread it.

CUTTING INTERNAL THREADS

The tap is held by the square in tap wrench and is started into the hole by turning clockwise for right hand threads. Care must be taken to start the tap straight in line with the hole. As the tap is turned it cuts into the metal and starts to lead into the hole. The metal chips flow into the flute spaces and will cause the tap to turn hard unless the chips are broken. The chips are broken and pressure on the tap is released by reversing the tap direction every $\frac{1}{4}$ or $\frac{1}{2}$ a revolution depending on the material being tapped. This action is continued until the tap passes through the part or the desired depth of the thread has been reached. In cases where it is necessary to tap a hole that does not pass through the part, or so called blind hole, be sure to provide clearance at the bottom to accommodate chips and the chamfer section of the tap.

WHEN USING TAPS

- DO** drill correct size hole (see chart)
- DO** countersink hole before tapping
- DO** keep tap straight in line with the hole being tapped
- DO** reverse tap during use to break up chips
- DO** use correct lubrication
- DO** provide rigid holding of part being tapped

The operation of any cutting tool can result in foreign objects being thrown into the eyes, which can result in severe eye damage. Always wear safety glasses or eye shields before starting cutting tool operation.

- DON'T** use too small a tap drill
- DON'T** crowd tap – Tap should be turned backwards slightly every $\frac{1}{4}$ to $\frac{1}{2}$ turn to clear chips from tap flutes.
- DON'T** fail to clean tap before storage

MAINTENANCE

The importance of using a sharp tap cannot be over emphasized. As taps require precision sharpening equipment, it is recommended that dull or damaged tools be replaced.

DIES

WHAT IS A DIE? – WHAT DOES IT DO?

A die is a precision tool used in cutting external or outside threads. Dies cut external threads such as on a bolt.

TOOLS REQUIRED TO CUT AN EXTERNAL THREAD

1. A die of the correct size and thread form
2. A die stock to hold the die
3. Lubricating or cutting oil

HOW TO USE A DIE

After selecting the proper die, position and hold in the die stock, with the starting side next to the guide, by means of a set screw which tightens against the edge of the die. Next place the adjustable guide side of the die stock on the rod or bolt to be threaded.

With the rod or bolt in position, adjust the guides by turning the chuck plate counter clockwise until guides touch the rod or bolt. Clamp plate is then held in place by tightening the two knurled screws. The adjustable guides properly set assure cutting straight threads.

CUTTING EXTERNAL THREADS

Rigidly secure the correct size rod or bolt, preferably 0.005 to 0.010 undersize and beveled for ease in starting and turn the die clockwise. As the die starts to cut, chips will flow and should be broken by reversing every $\frac{1}{4}$ to $\frac{1}{2}$ turn. Periodic application of cutting oil will help in cutting smooth threads and in prolonged die life. Continue the forward and reversing action until the desired length of thread has been cut.

RENEWING THREADS

Damaged threads are readily repaired by proceeding as for cutting new threads. Care should be taken to start the die in the previously formed thread.

WHEN USING DIES

- DO** select the right size die
- DO** keep die at right angle to work piece
- DO** use correct lubrication
- DO** chamfer or bevel end of work before threading
- DO** clean and store dies in proper spaces after use

The operation of any cutting tool can result in foreign objects being thrown into the eyes, which can result in severe eye damage. Always wear safety glasses or eye shields before commencing cutting tool operation.

DON'T crowd the die – die should be turned backwards slightly every $\frac{1}{4}$ to $\frac{1}{2}$ turn to clear chips from die

DON'T jam the die against the head or shoulder when threading close.

1) Steel	Lard oil, cutting oil, or Crisco
2) Cast Iron	Dry or air blast
3) Aluminum	Kerosene or Kerosene lightly mixed with lard oil
4) Brass	Kerosene
5) Magnesium	Kerosene
6) Zinc	Kerosene
7) Bakelite	Dry
8) Hard Rubber	Dry
9) Bronze	Kerosene or Kerosene mixed with lard oil
10) Stainless steel	Kerosene mixed with lard oil

Additional lubricants for production or industrial uses may be obtained by consulting commercial distributors of oils and greases.

TAP SIZE	DEC EQUIV.	FRAC DRILL SIZE	TAP SIZE	DEC. EQUIV	FRAC. DRILL SIZE	TAP SIZE	DEC EQUIV	FRAC DRILL SIZE
4 – 40	0.0890	3/32	5/8 – 11	0.5312	37/64	7mm -1	0.234	15/64
6 – 32	0.1065	7/64	5/8 – 18	0.5781	19/32	8mm – 1	0.277	9/32
8 – 32	0.1360	9/64	11/16-11	0.5937	5/8	8mm-1.25	0.265	17/64
10-32	0.1590	5/32	11/16-16	0.6250	21/32	¼-19BSP	0.453	29/64
10-24	0.1495	5/32	¾-10	0.6562	11/16	9mm-1	0.3125	5/16
12-24	0.1770	11/64	¾-16	0.6875	49/64	9mm-1	0.3125	5/16
¼-20	0.2010	13/64	7/8-9	0.7656	13/16	10mm-1	0.359	23/64
¼-28	0.2130	7/32	7/8-14	0.8125	7/8	10mm-1.25	0.3437	11/32
5/16-18	0.2656	17/64	1 in. -12	0.9219	59/64	10mm-1.5	0.339	11/32
5/16-24	0.2656	17/64	1 in. -14	0.9375	15/16	11mm-1.5	0.375	3/8
3/8-24	0.3281	21/64	3mm-0.5	0.0995	3/32	12mm-1.5	0.406	13/32
3/8-16	0.3125	5/16	3mm-0.6	0.0937	3/32	12mm-1.75	0.406	13/32
1/8 PIPE	0.3125	5/16	3.5mm-0.6	0.116	1/8	14mm-1.25	0.515	33/64
¼ PIPE	0.437	25/64	4mm-0.7	0.1285	1/8	14mm-2	0.469	15/32
7/16-20	0.3906	3/8	4mm-0.75	0.125	1/8	16mm-1.5	0.578	37/64
7/16-14	0.3750	27/64	4.5mm-0.75	0.141	9/64	16mm-2	0.656	35/64
½-13	0.4219	29/64	5mm-0.8	0.166	11/64	18mm-1.5	0.6614	21/32
½-20	0.4531	31/64	5mm-.09	0.161	5/32	18mm-2.5	0.609	39/64
9/16-12	0.4844	33/64	6mm-1	0.196	13/64	1/8-28BSP	0.3281	21/64
9/16-18	0.5156	17/32	6.3mm-1	0.213	7/32	1 in.-8	0.8750	7/8

MAINTENANCE

The importance of using sharp dies cannot be overemphasized. As dies require precision sharpening equipment, it is recommended that dull or damaged tools be replaced.

EXTRA INFORMATION

EFFECT OF HOLE OR BOLT SIZE ON HEIGHT OF THREAD

When cutting threads, if the tap or die cuts away metal the full form or depth of the thread, the result is 100% height of thread on the work. Therefore, the height of thread is determined by the size of the drilled hole for tapping, or the size of bolt or rod when using a die. If the size of the hole is the same size as the minor diameter of the tap, the thread produced would be 100% height.

When the hole is larger than the minor diameter of the tap or the size of the bolt or rod is less than the major diameter of the die, the height of the thread cut will be less than 100%. Thus to vary the height of the thread, one must vary the size of the drilled hole or size of the bolt or rod.

A 100% thread is only 5% stronger than a 75% thread height, but requires 3 times the power to turn the tap. A 100% thread height does not give a tighter fit. It only serves to overload the tools and possibly cause premature tool failure.

The recommended thread height is 75% for average use and the Tap Drill Reference Chart gives the correct drill size for each size tap. One should also remember in preparing bolts or rods for cutting of the external thread, the diameter of the bolt or rod should be from 0.005 to 0.010 under the nominal size.

The thread gauge will help in determining the correct number of threads per inch on a bolt or nut, or pitch on metric sizes. The gauge is provided with blades each marked with a number corresponding to the threads per inch or pitch. For example: "16" on the blade means 16 threads per inch. The part is checked by placing the correct blade in such a manner that all teeth or notches align properly with the threads on the bolt or nut. As a substitute for a thread gauge, a tap may be used in the same manner as described above.

The bolt diameter is established by measuring the outside diameter with micrometers. Normally bolts are manufactured with the diameter slightly under the nominal size. For example; a 5/16 inch bolt will probably measure 0.305, instead of 0.3125, when measure in this manner.

LUBRICATION

Selection and application of the proper lubricant has a very important bearing on the success of the thread cutting operation. Longer tap and die life plus smoother, cleaner, and more accurately formed threads will be the benefits. Once the proper lubricant has been selected it should be directed with an oil can, brush, or other convenient method to the cutting edges during threading operation. Recommended lubricants most readily available for the home work shop use are listed with the materials to be threaded.

Reference

Walker, John R. *Modern Metalworking*. South Holland, Illinois: The Goodheart-Wilcox Company, Inc, 1976.

UCSB College of Engineering Machine Shop Safety Handout.